

# MANAGEMENT SCIENCE AND ENGINEERING

The Department of Management Science and Engineering is concerned with how best to organize resources – people, money, and materials – in our information-intensive, technology-based economy. The degree programs in MS&E prepare students to solve practical problems based on fundamental engineering principles. The department has strong research and teaching programs in decision and risk analysis, economics, engineering management, entrepreneurship, finance, information, operations research, organizations, production and manufacturing, strategy, systems analysis, and technology policy.

The undergraduate curriculum in Management Science and Engineering provides students training in the fundamentals of engineering systems analysis to prepare them to plan, design, and implement complex economic and technological management systems where a scientific or engineering background is necessary or desirable. Graduates will be prepared for work in a variety of career paths, including facilities and process management, investment banking, management consulting, or graduate study in industrial engineering, operations research, economics, public policy, medicine, law, or business.

## OBJECTIVES AND OUTCOMES FOR MANAGEMENT SCIENCE & ENGINEERING

### **Objectives:**

*Principles and Skills:* Provide our students with a basic understanding of management science and engineering principles, including analytical problem solving and communication skills.

*Preparation for Practice:* Prepare our students for practice in a field that sees rapid changes in tools, problems, and opportunities.

*Preparation for Continued Growth:* Prepare our students for graduate study and self development over an entire career, and

*Preparation for Service:* Develop in our students the awareness, background, and skills necessary to become responsible citizens, employees, and leaders

### **Outcomes:**

An ability to apply knowledge of math, science, and engineering;

An ability to design and conduct experiments;

An ability to design a system or components to meet desired needs;

An ability to identify, formulate, and solve engineering problems;

An ability to use techniques, skills, and modern engineering tools necessary for engineering practice;

An ability to function on multidisciplinary teams;

An ability to communicate effectively;

A recognition of the need for and an ability to engage in life-long learning;

Background necessary for admission to top professional graduate engineering or business programs;

An understanding of professional and ethical responsibility;

The broad education necessary to understand the impact of engineering solutions in a global and societal context; and

A knowledge of contemporary issues pertinent to the field of management science and engineering.

## PROGRAM DESCRIPTION

The program builds on the foundational courses for engineering including calculus, engineering fundamentals, and physics or chemistry. The department core, taken for all concentrations, includes courses in computer science, information, organization theory, mathematical modeling, optimization, probability, statistics, and finance or production. Through the core, all students in the program are exposed to the breadth of faculty interests, and are in a good position to choose a concentration during the junior year.

The five concentrations are designed to allow a student to explore one area of the department in greater depth. They are:

1. *Financial and Decision Engineering*: Focuses on the design and analysis of financial and strategic plans. It features accounting, decision analysis, economics, finance, investment science, and stochastic models.
2. *Operations Research*: Provides a more mathematical program, based on algorithms, theory, and applications in economics and operations.
3. *Organization, Technology, and Entrepreneurship*: Focuses on the understanding and design of organizations, particularly technology-based issues. It features courses on innovation, product development, and entrepreneurship as well as work and manufacturing systems, and information systems and human-computer interaction.
4. *Production and Operations Management*: Focuses on the design and analysis of manufacturing, production and service systems.
5. *Policy and Strategy*: Focuses on the design and analysis of public policies and corporate strategies, especially those with technology-based issues. It features grounding in microeconomics and modeling approaches as well as courses with a policy focus in topics such as national security, energy and environment, and health care and courses with a strategy focus in topics such as entrepreneurship, innovation, and product development.

The program for students in all concentrations builds on a strong engineering foundation. The required mathematics courses include calculus of single and multiple variables, linear algebra, probability, statistics, and stochastic models. At least eleven units of science are required, including two courses in chemistry or physics. The required and elective mathematics and science requirements can be met by the approved courses, listed earlier in this handbook, or by PHYSICS 21, 22, 23, 24, 25, or 26, PSYCH 55 (cognitive psychology) or 70 (social psychology), or AP credit for chemistry, mathematics, or physics (AP units must be approved by the SoE Dean's office in 201 Terman).

The program includes three Engineering Fundamental courses, in addition to the two engineering fundamental courses included in the department core, ENGR 60 and MS&E 111/ENGR 62. One of the fundamentals must be CS 106A, one is elective, and the other is either ENGR 40, which provides some background and lab experience in electrical engineering, or ENGR 25, which presents basic science and engineering principles of biotechnology.

The Technology in Society requirement is satisfied by a subset of the courses approved by the School of Engineering, particularly those that emphasize social responsibility (refer to the TIS table in this section or the asterisked items in Figure 3-3). Some of these courses are also included in some of the concentrations; any given course can be used to satisfy either the Technology in Society or depth requirement, but not both.

The Writing in the Major (WIM) requirement can be met by three restricted electives in the program, MS&E 152W, 193W, or 197. It is up to the students to ensure that their programs include at least one of them, either in their concentrations or their Technology in Society courses. Students are welcome to take more than one WIM course, and WIM courses can be used to satisfy other requirements.

The department core comprises courses in computer science, deterministic optimization, information, organization theory, a senior project, and finance or production. Students in Financial and Decision Engineering must take two finance courses including MS&E 142. Students in Production and Operations Management must take MS&E 160. Students in Operations Research must take both MS&E 142 and MS&E 160.

Some of the concentrations include courses with prerequisites (ECON 1 or PSYCH 1) not included in the degree program, but those courses could be used to satisfy the General Education Requirements (GERs).

Although there are prerequisites for most MS&E courses, we encourage students to take some MS&E courses in their freshman and sophomore year to learn more about the department. Introductory courses without prerequisites include MS&E 107, 131, 152, and 180. Introductory courses with calculus prerequisites include: E60, MS&E 111, and MS&E 120.

For information about an MS&E minor, see the “Minors and Honors” section in this Handbook. In addition to the B.S. degree, the MS&E Department offers Master of Science and Doctor of Philosophy degrees in Management Science and Engineering.

If you would like more information about our degree programs, please visit Lori Cottle, the MS&E Student Services Manager, in Terman Engineering Center Room 306. Students are encouraged to plan their academic programs as early as possible, ideally in the freshman or sophomore year. Please do not wait until you are declaring a major to consult with us. This is particularly important if you would like to study overseas or pursue another major or minor.

## RESEARCH EXPERIENCE FOR UNDERGRADUATES

Our Research Experience for Undergraduates (REU) program offers students the opportunity to work closely with a faculty member during the summer quarter, and get paid to do so full-time. We give priority to our declared majors for REU positions. Information is emailed to all declared majors when applications become available during the winter quarter.

## REQUIREMENTS: BACHELOR OF SCIENCE DEGREE IN MS&E

### MATH AND SCIENCE (45 UNITS MINIMUM)

COURSE	TITLE	UNITS	QTR.
<b>MATH (32 units minimum)</b>			
MATH 41	Single Variable Calculus (AP/IB credit may be used)	5	A
MATH 42	Single Variable Calculus (AP/IB credit may be used)	5	A,W
MATH 51	Linear Algebra and Diff. Calculus of Several Vars.	5	A,W,S
MATH 53	Ordinary Differential Equations with Linear Algebra	5	A,W,S
STATS 110	Statistical Methods in Engineering and the Physical Sciences	4-5	A
or STATS 200	Introduction to Statistical Inference	3	W
MS&E 120	Probabilistic Analysis	5	A
MS&E 121	Introduction to Stochastic Modeling	4	W

<b>Science (11 units minimum)</b>			
<i>One of the following three eight-unit sequences:</i>			
CHEM 31B/X	Chemical Principles (AP/IB credit may be used)	4	A,W
and CHEM 33	Structure and Reactivity	4	W,S
PHYS 21&22	Mechanics and Heat & Lab (AP/IB credit may be used)	4	A
and PHYS 23&24	Electricity and Optics & Lab (AP/IB credit may be used)	4	W
PHYS 41	Mechanics (AP Physics C /IB credit may be used)	4	W
and PHYS 43	Electricity and Magnetism (AP Physics C/IB credit may be used)	4	S
And also	Science Elective from SoE approved list (Fig. 3-2), or PSYCH 55, or PSYCH 70	3	A,W,S

Additional Math or Science elective, if needed to reach 45 total units, from the SoE approved lists, or PSYCH 55 or 70.

**TECHNOLOGY IN SOCIETY (ONE COURSE, 3-5 UNITS)**

COURSE	TITLE	UNITS	QTR.
STS 101/101Q	Science, Technology, and Contemporary Society	4-5	A
STS 110	Ethics and Public Policy	5	W
STS 115	Ethical Issues in Engineering	4	S
STS 160	Controversy & Closure: The Politics of Technical Expertise (not given 2008-09)	4	
STS 170	Technology in Modern Security Discourse (not given 2008-09)	4	
STS 279	Technology, Policy, & Management in Newly-Industrializing Countries (not given 2008-09)	3-4	
COMM 120	Digital Media in Society	5	S
COMM 169	Computers and Interfaces: Psychological and Social Responsibility Issues	5	W
CS 181	Computers, Ethics, and Public Policy	3-4	S
MS&E 181	Issues in Technology and Work for a Post-Industrial Economy	3	A
MS&E 193	Technology in National Security	3	A

**ENGINEERING FUNDAMENTALS (AT LEAST 3 COURSES; 11-15 UNITS)**

COURSE	TITLE	UNITS	QTR
CS 106A	Programming Methodologies (AP/IB credit may be used)	5	A,W,S
ENGR 25	Biotechnology	3	S
or ENGR 40	Introductory Electronics	5	A,S
One other engineering fundamental from SoE approved list (E60 and E62 may not be used)		3-5	A,W,S

**WRITING IN THE MAJOR (ONE COURSE)**

MS&E 152W, MS&E 193W, and MS&E 197, taken as TIS or depth, fulfill requirement.

**ENGINEERING DEPTH: CORE (7 COURSES; 25-29 UNITS)**

COURSE	TITLE	UNITS	QTR.
CS 106B/X or	Programming Abstractions	5	A,W,S
CS 103 or	Mathematical Foundations of Computing	5	W
CME 108	Introduction to Scientific Computing	3-4	W
ENGR 60	Engineering Economy	3	A,W
MS&E 108	Senior Project	5	W
MS&E 111	Introduction to Optimization	4	A,S
MS&E 130 or	Information Systems and Networks or	3	S
MS&E 134	Organizations and Information Systems	4	W
MS&E 142 or	Investment Science or	3	A
MS&E 260	Analysis of Production and Operating Systems	4	A
MS&E 180	Organizations: Theory and Management	4	A,S

## ENGINEERING DEPTH: CONCENTRATION (20-30 UNITS)

Choose one of the following five concentrations:

### FINANCIAL AND DECISION ENGINEERING (7 COURSES; 27-29 UNITS)

COURSE	TITLE	UNITS	QTR.
<i>Students must choose MS&amp;E 142 in Engineering Depth – Core (above)</i>			
ECON 50	Economic Analysis I	5	A,W,S
ECON 51	Economic Analysis II	5	W,S
MS&E 140	Accounting for Managers and Entrepreneurs	4	A,W
MS&E 152	Introduction to Decision Analysis (WIM)	4	S
MS&E 245G or MS&E 247S	Finance I or International Investments	4 3	A Sum
<i>Two of the following seven courses:</i>			
ENGR 145	Technology Entrepreneurship	4	A,W
or FINANCE 323	International Financial Management	4	W
or MS&E 107	Interactive Management Science	3	A
or MS&E 223	Simulation	3	S
or MS&E 250A	Engineering Risk Analysis	3	W
or MS&E 260	Production and Operating Systems	4	A
or STATS 240	Statistical Methods in Finance	3-4	A

### OPERATIONS RESEARCH (8 COURSES; 24-27 UNITS)

COURSE	TITLE	UNITS	QTR.
MATH 113	Linear Algebra and Matrix Theory	3	A,W
MATH 115	Functions of a Real Variable	3	A,W
MS&E 112	Network and Integer Optimization	3	W
MS&E 142	Investment Science (cannot also be used for core)	3	A
or MS&E 260	Production and Operating Systems (cannot also be used for core)	4	A
MS&E 152	Introduction to Decision Analysis	3-4	S
MS&E 241	Economic Analysis	3-4	W
MS&E 251	Stochastic Decision Models	3	W
STATS 202	Data Analysis	3	A

### ORGANIZATION, TECHNOLOGY, AND ENTREPRENEURSHIP (7 COURSES; 20-24 UNITS)

COURSE	TITLE	UNITS	QTR.
<i>At least one of the following three courses:</i>			
ECON 50	Economic Analysis I	5	W,S
PSYCH 70	Introduction to Social Psychology	4	S
SOC 114	Economic Sociology	5	A
<i>At least two of the following three courses:</i>			
ENGR 145	Technology Entrepreneurship	4	A,W
MS&E 175	Innovation, Creativity, and Change	4	W
MS&E 181	Issues in Technology and Work	4	S
<i>At least 4 of the following 7 courses (may also include omitted course from above: ENGR 145, MS&amp;E 175, or MS&amp;E 181):</i>			
<i>Organizations and Technology:</i>			
CS 147	Introduction to Human-Computer Interaction Design	3-4	A
MS&E 134	Organizations and Information Systems (cannot also be used for core)	4	W
MS&E 184	Technology and Work	3	S
MS&E 185	Global Work	4	S
MS&E 269	Quality Engineering (not given 2008-09)	4	
<i>Entrepreneurship and Innovation:</i>			
MS&E 140	Accounting for Managers and Entrepreneurs	3-4	A,W
MS&E 266	Management of New Product Development	3-4	W

**POLICY AND STRATEGY (7 COURSES; 27-32 UNITS)**

COURSE	TITLE	UNITS	QTR.
ECON 50	Economic Analysis I	5	A,W,S
ECON 51	Economic Analysis II	5	A,W
MS&E 190	Policy and Strategy Analysis	5	S
<i>At least four of the following nine courses, including at least one course in policy and at least one course in strategy:</i>			
<i>Policy:</i>			
MS&E 193	Technology and National Security	3	A
MS&E 197	Ethics and Public Policy	5	W
MS&E 243	Energy and Environmental Policy Analysis	3	S
MS&E 248	Economics of Natural Resources	3-4	A
MS&E 292	Health Policy Modeling	3	W
<i>Strategy:</i>			
ENGR 145	Technology Entrepreneurship	4	A,W
MS&E 175	Innovation, Creativity, and Change	3-4	W
MS&E 266	Management of New Product Development	3-4	W

**PRODUCTION AND OPERATIONS MANAGEMENT (7 COURSES; 26-30 UNITS)**

COURSE	TITLE	UNITS	QTR.
<i>Students must choose MS&amp;E 160 in Engineering Depth – Core (above)</i>			
ECON 50	Economic Analysis I	5	A,W,S
ECON 51	Economic Analysis II	5	W,S
MS&E 140	Accounting for Managers and Entrepreneurs	3-4	A,W
MS&E 152	Introduction to Decision Analysis	4	S
<i>Three of the following nine courses:</i>			
MS&E 142	Investment Science	3	A
or MS&E 245G	Finance I	4	A
MS&E 262	Supply Chain Management	3	S
MS&E 263	Internet-Enabled Supply Chains (not given 2008-09)	3	
MS&E 264	Sustainable Product Development and Manufacturing	3	A
MS&E 265	Supply Chain Logistics	4	S
MS&E 266	Management of New Product Development	3-4	W
MS&E 267	Operations Strategy	3	S
MS&E 269	Quality Engineering (not given 2008-09)	4	

Engineering fundamentals, engineering depth (core), and engineering depth (concentration) must total a minimum of 60 units.

Courses used to satisfy the math, science, technology in society, or engineering fundamental requirements may not also be used to satisfy an engineering depth requirement.

# MS&E: Financial and Decision Engineering

*Typical Sequence of Courses*

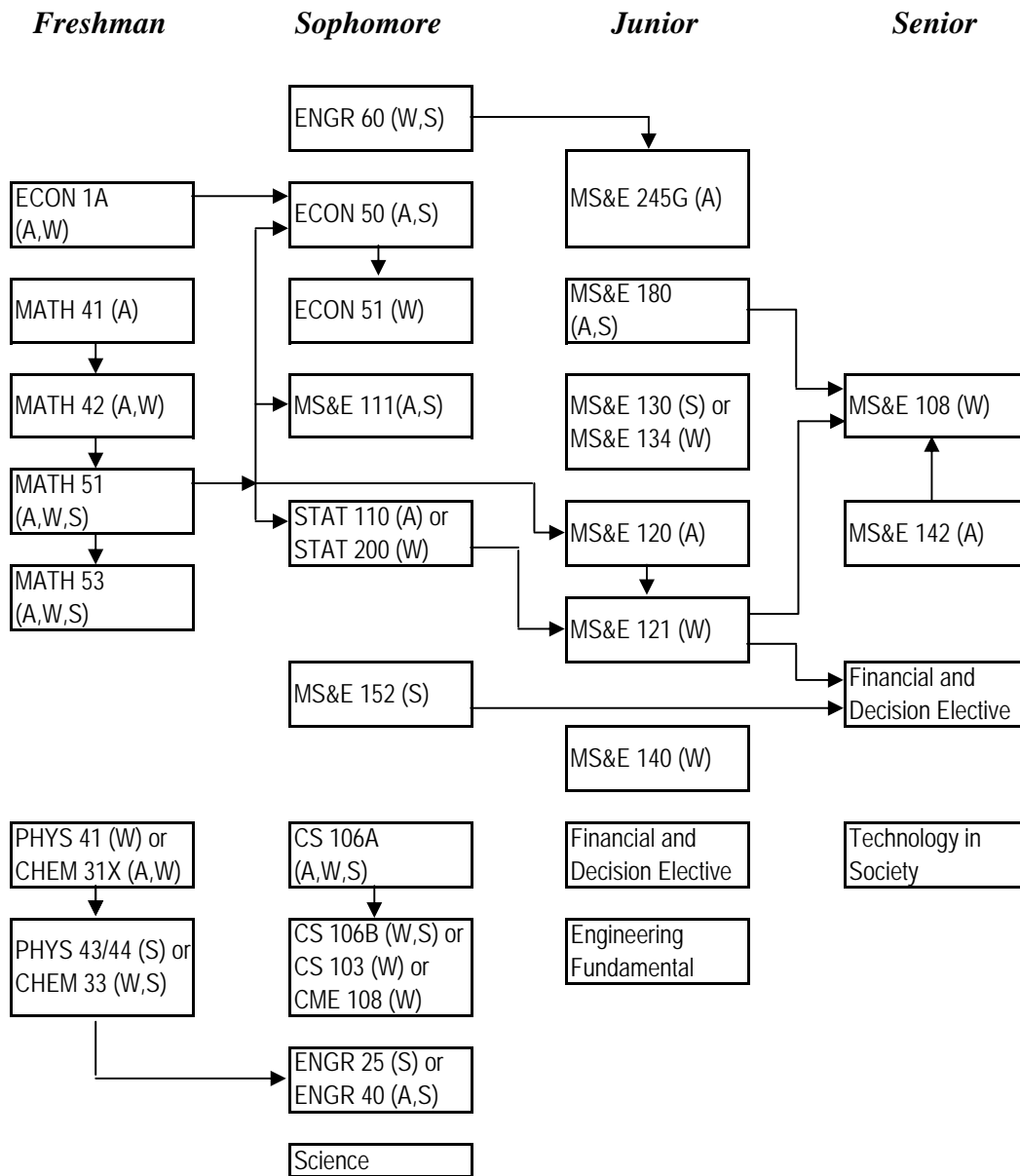

\* Arrows represent direct prerequisites

# MS&E: Operations Research

*Typical Sequence of Courses*

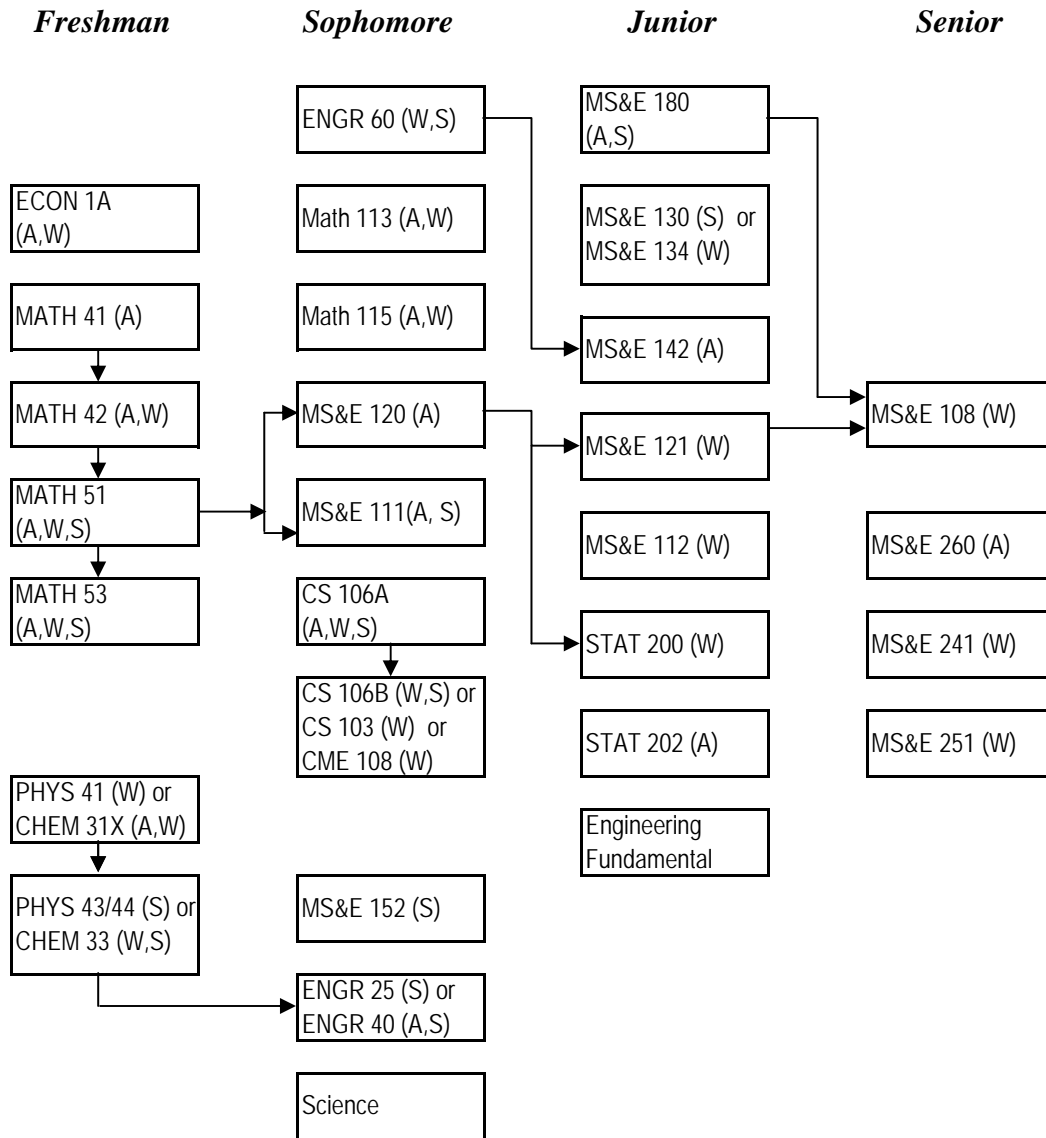

\* Arrows represent direct prerequisites

# MS&E: Organization, Technology, and Entrepreneurship

*Typical Sequence of Courses*

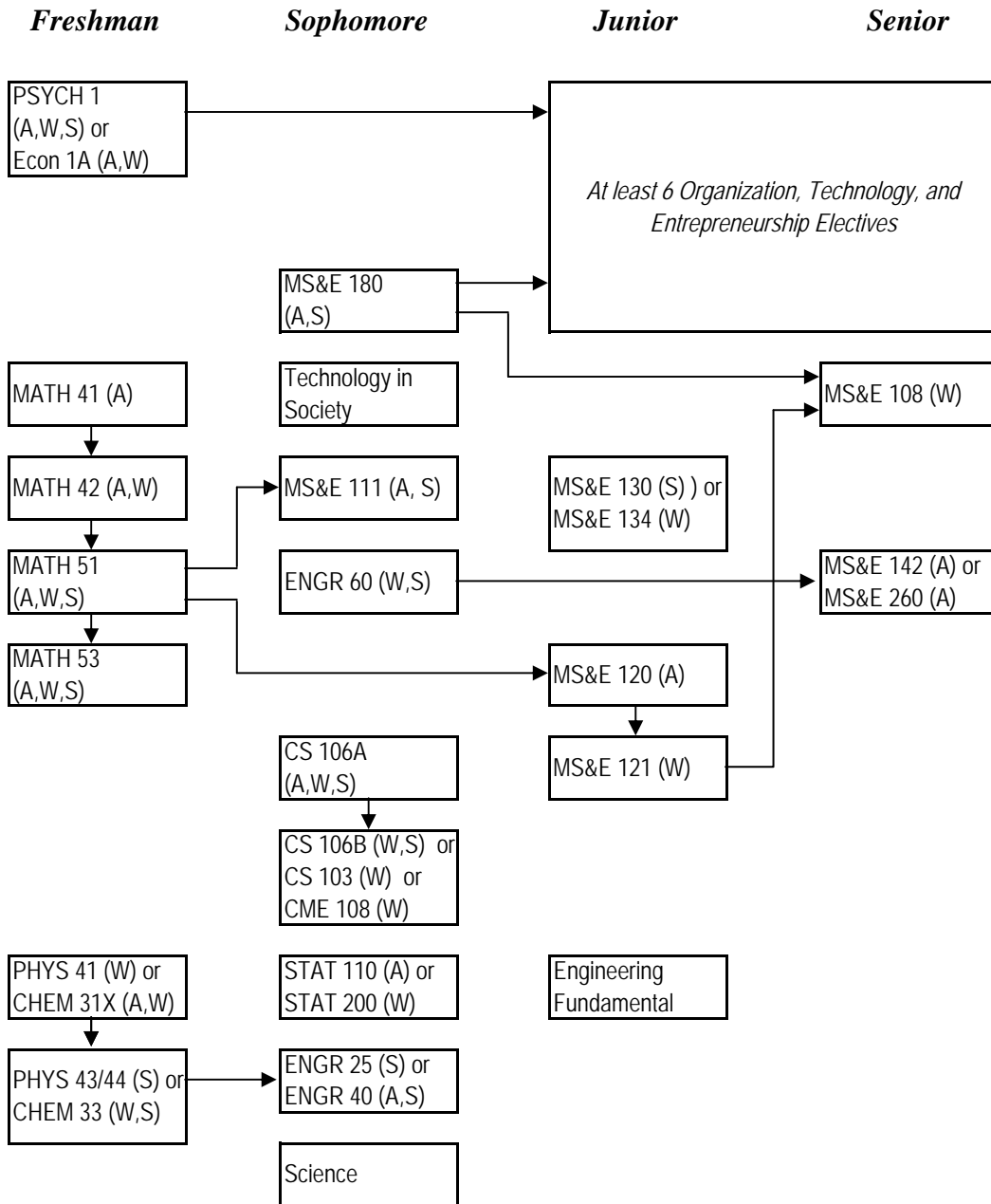

\* Arrows represent direct prerequisites

# MS&E: Production and Operations Management

Typical Sequence of Courses

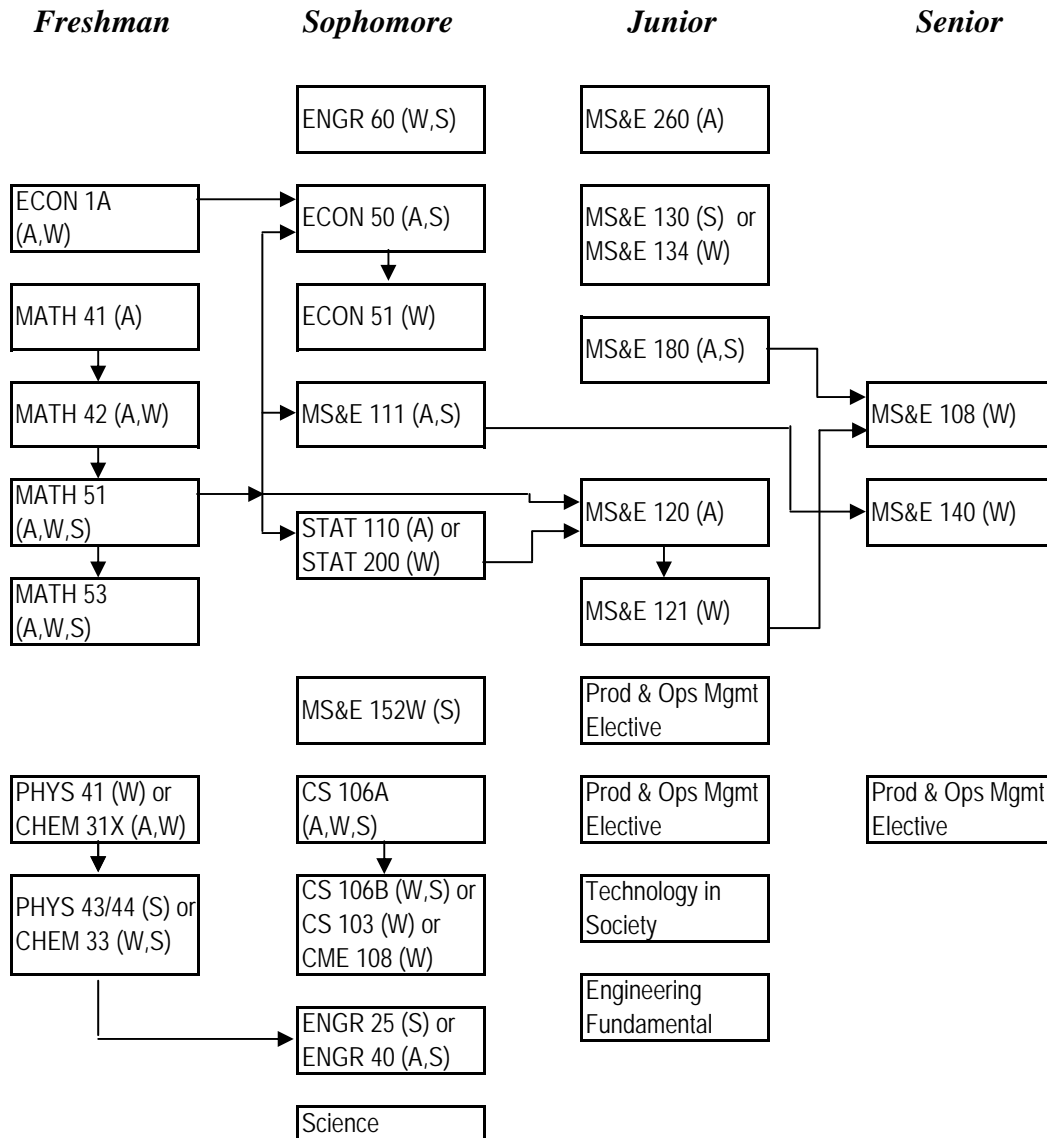

\* Arrows represent direct prerequisites

# MS&E: Policy & Strategy

*Typical Sequence of Courses*

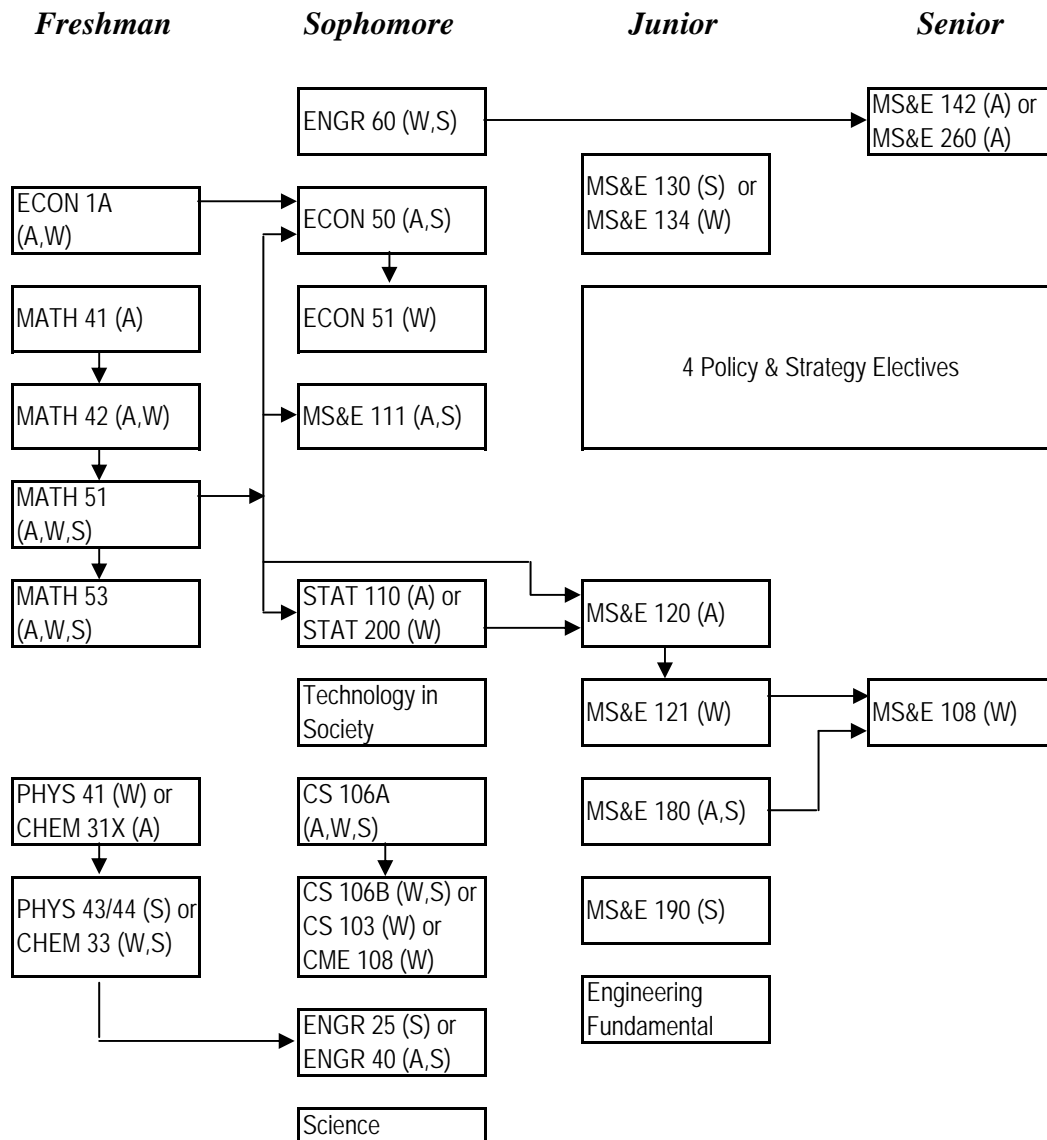

\* Arrows represent direct prerequisites

## Management Science & Engineering

*Sample Program Without AP/IB Math Credit*

	<i>Fall</i>				<i>Winter</i>				<i>Spring</i>			
	Math/				Math/				Math/			
	Class	Sci.	Engr	Other	Class	Sci.	Engr	Other	Class	Sci.	Engr	Other
<i>Freshman</i>	IHUM	-	-	5	IHUM	-	-	5	IHUM	-	-	5
	MATH 41	5	-	-	MATH 42	5	-	-	PWR 1	-	-	4
	GER	-	-	3	ECON 1/PSYCH 1	-	-	5	MATH 51	5	-	-
	Elective	-	-	3								
	<i>Subtotals</i>	<i>5</i>	<i>0</i>	<i>11</i>	<i>Subtotals</i>	<i>5</i>	<i>0</i>	<i>10</i>	<i>Subtotals</i>	<i>5</i>	<i>0</i>	<i>9</i>
	<b>Total</b>			<b>16</b>	<b>Total</b>			<b>15</b>	<b>Total</b>			<b>14</b>
<i>Sophomore</i>	MATH 53	5	-	-	PHYS23&24/CH31X	4	-	-	Science/CHEM 33	4	-	-
	STATS 110/200	5	-	-	CS 106A	-	5	-	CS 106B	-	5	-
	PHYS 21&22/Science	4	-	-	ENGR 60	-	3	-	PWR 2	-	-	4
	ECON 50/Concen	-	5	-	ECON 51/Concen	-	5	-	MS&E 152W/MS&E 180	-	4	-
	<i>Subtotals</i>	<i>14</i>	<i>5</i>	<i>0</i>	<i>Subtotals</i>	<i>4</i>	<i>13</i>	<i>0</i>	<i>Subtotals</i>	<i>4</i>	<i>9</i>	<i>4</i>
	<b>Total</b>			<b>19</b>	<b>Total</b>			<b>17</b>	<b>Total</b>			<b>17</b>
<i>Junior</i>	MS&E 111	-	4	-	MS&E 121	4	-	-	E25/E40	-	3	-
	MS&E 120	5	-	-	MS&E 134/Concer	-	4	-	Fund. Elective	-	3	-
	MS&E 180/Concen	-	4	-	Concentration/TIS	-	4	-	GER	-	-	4
	Concentration	-	3	-	GER	-	-	3	Elective	-	-	5
	<i>Subtotals</i>	<i>5</i>	<i>11</i>	<i>0</i>	<i>Subtotals</i>	<i>4</i>	<i>8</i>	<i>3</i>	<i>Subtotals</i>	<i>0</i>	<i>6</i>	<i>9</i>
	<b>Total</b>			<b>16</b>	<b>Total</b>			<b>15</b>	<b>Total</b>			<b>15</b>
<i>Senior</i>	MS&E 142 or 260	-	4	-	MS&E 108	-	5	-	GER	-	-	3
	TIS/Concentration	-	4	-	Concentration	-	4	-	Electives	-	-	9
	Concentration	-	4	-	GER	-	-	3				
	<i>Subtotals</i>	<i>0</i>	<i>12</i>	<i>0</i>	<i>Subtotals</i>	<i>0</i>	<i>9</i>	<i>3</i>	<i>Subtotals</i>	<i>0</i>	<i>0</i>	<i>12</i>
		<b>Total</b>			<b>12</b>	<b>Total</b>			<b>12</b>	<b>Total</b>		

Total Math & Science Units: 46

Total Engineering Units: 73

Total Other Units: 61

**Total Units: 180**

## Management Science & Engineering

Sample Program With AP/IB Math Credit

	<i>Fall</i>			<i>Winter</i>			<i>Spring</i>					
	Math/ Class	Sci.	Engr	Other	Math/ Class	Sci.	Engr	Other	Math/ Class	Sci.	Engr	Other
<i>Freshman</i>	IHUM	-	-	5	IHUM	-	-	5	IHUM	-	-	5
	MATH 51	5	-	-	MATH 53	5	-	-	PWR 1	-	-	4
	Electives	-	-	6	CHEM 31X/PHYS	4	-	-	CHEM 33/PHYS	4	-	-
					ECON 1/PSYCH 1	-	-	5	GER	-	-	3
	<i>Subtotals</i>	<i>5</i>	<i>0</i>	<i>11</i>	<i>Subtotals</i>	<i>9</i>	<i>0</i>	<i>10</i>	<i>Subtotals</i>	<i>4</i>	<i>0</i>	<i>12</i>
<b>Total</b>	<b>16</b>			<b>Total</b>	<b>19</b>			<b>Total</b>	<b>16</b>			
<i>Sophomore</i>	STATS 110/200	5	-	-	CS 106A	-	5	-	E25/E40	-	3	-
	Science Elective	3	-	-	ENGR 60	-	3	-	CS 106B	-	5	-
	ECON 50/Concen	-	5	-	ECON 51/Concen	-	5	-	MS&E 111	-	4	-
	GER	-	-	3	PWR 2	-	-	4	MS&E 152W (or MS&E 180)	-	4	-
	<i>Subtotals</i>	<i>8</i>	<i>5</i>	<i>3</i>	<i>Subtotals</i>	<i>0</i>	<i>13</i>	<i>4</i>	<i>Subtotals</i>	<i>0</i>	<i>16</i>	<i>0</i>
<b>Total</b>	<b>16</b>			<b>Total</b>	<b>17</b>			<b>Total</b>	<b>16</b>			
<i>Junior</i>	MS&E 120	5	-	-	MS&E 121	4	-	-	Fundamental	-	3	-
	MS&E 180/Concer	-	4	-	MS&E 134/Elect	-	4	-	MS&E 130/Elect	-	-	3
	Concentration	-	4	-	Concentration/TIS	-	4	-	GER	-	-	4
	Concentration	-	3	-	GER	-	-	3	Electives	-	-	6
	<i>Subtotals</i>	<i>5</i>	<i>11</i>	<i>0</i>	<i>Subtotals</i>	<i>4</i>	<i>8</i>	<i>3</i>	<i>Subtotals</i>	<i>0</i>	<i>3</i>	<i>13</i>
<b>Total</b>	<b>16</b>			<b>Total</b>	<b>15</b>			<b>Total</b>	<b>16</b>			
<i>Senior</i>	MS&E 142 or 260	-	4	-	MS&E 108	-	5	-	Electives	-	-	12
	TIS/Concentration	-	4	-	Concentration	-	4	-				
	Elective	-	-	4	Elective	-	-	3				
	<i>Subtotals</i>	<i>0</i>	<i>8</i>	<i>4</i>	<i>Subtotals</i>	<i>0</i>	<i>9</i>	<i>3</i>	<i>Subtotals</i>	<i>0</i>	<i>0</i>	<i>12</i>
	<b>Total</b>	<b>12</b>			<b>Total</b>	<b>12</b>			<b>Total</b>	<b>12</b>		

Total Math & Science Units: 35  
 Total Engineering Units: 73  
 Total Other Units: 75  
**Total Units: 183**

## INSTRUCTIONS FOR DECLARING MAJOR IN MANAGEMENT SCIENCE AND ENGINEERING

We encourage students to declare as early as possible if they are seriously considering the major. The process consists of discussing your plans with the Student Services Manager and meeting prospective advisors until you find a faculty member you want to work with. The MS&E major offers a wide variety of options and students can receive much better guidance once they have declared. Paperwork for the declaration process is available at

<http://www.stanford.edu/dept/MSandE/academics/bsdeclare.html>.

1. Complete the MS&E counseling form, available at  
<http://www.stanford.edu/dept/MSandE/academics/bsdeclare.html>.
2. Go into Axess and declare MS&E as your major. Your declaration will be routed to Lori Cottle, Student Services Officer, for approval. Online approval will be given after steps 1-5 are completed.
3. Meet with Lori Cottle in Terman 306 for a tentative advisor assignment or choose an advisor from the MS&E list of available advisors, available at  
<http://www.stanford.edu/dept/MSandE/academics/bsdeclare.html>.
4. Take the counseling form and an unofficial copy of your transcript or Axess grade printout to your new faculty advisor for a declaration advising session.
5. Bring the completed, signed form to Lori Cottle in Terman 306, who will then approve your online declaration. You will be sent an automatic email from the system after final approval has been given.

**Note: The online version of the UGHB is considered the definitive and final version of SoE requirements for each major.** Since corrections or updates may have been made after this Handbook went to press in August 2008, download the online MS&E program sheet from [ughb.stanford.edu](http://ughb.stanford.edu) to ensure you are using an accurate major plan.



**Stanford University • School of Engineering**  
**Management Science & Engineering**  
**Concentration: \_\_\_\_\_**

**2008-2009 Program Sheet**

*Final Version of the completed and signed program sheet due to the department no later than one month prior to the last quarter of senior year.*

**\*Follow all requirements as stated for the year of the program sheet used.\***

Name: \_\_\_\_\_  
 Email: \_\_\_\_\_  
 Date: \_\_\_\_\_

SU ID: \_\_\_\_\_  
 Local Phone: \_\_\_\_\_  
 Date B.S. expected: \_\_\_\_\_

**Mathematics and Science Requirements**

Dept	Course	Title	Transfer/AP Approval			Units	Grade
			✓ if Transfer	Initials	Date		
<i>Mathematics (32 units minimum)</i>							
MATH	41	Single Variable Calculus				5	
MATH	42	Single Variable Calculus				5	
MATH	51	Multi-Variable Calculus (req'd)				5	
MATH	53	ODE with Linear Algebra (req'd)				5	
MS&E	120	Probabilistic Analysis (req'd)				5	
MS&E	121	Intro to Stochastic Modeling (req'd)				4	
STAT		110 or 200 (req'd)				5	
<i>Mathematics Unit Total (32 units minimum)</i>							

*Science (11 units minimum; see Note 1)*

<i>Science Unit Total (11 units minimum)</i>							
<i>Mathematics and Science Unit Total (45 units minimum)</i>							

**Technology in Society Requirement (1 course req'd; see note 2)**

--	--	--	--	--	--	--	--

**NOTES**

- \* This form is available as an Excel file at <http://ughb.stanford.edu/>. The printed form must be signed by the advisor and, if
  - \* Read all emails from the Office of Student Affairs; this is the SoE's only method of conveying key information to Eng
  - \* All courses listed on this form must be taken for a letter grade if offered by the instructor.
  - \* Minimum Combined Grade Point Average for all courses in Engineering Fundamentals and Engineering Depth is 2.0.
  - \* Transfer and AP credits in Math, Science, Fundamentals, & TIS must be approved by the SoE Dean's office. Transfer
  - \* All courses listed on this form must only be included under one category. Delete courses not taken.
- (1) Eleven units of science required, including either Physics 43/45, or Physics 21/22/23/24, or Chemistry 31X/33, or  
 (2) MS&E-approved TIS courses: STS 101/201, 110, 115, 160, 170, 279, COMM 120, 169, CS 181, MS&E 181, 193.

*program sheet continues on page 2*

## Management Science and Engineering Program Sheet (continued)

### Engineering Fundamentals and Engineering Depth

Dept	Course	Title	Transfer/AP Approval			Units	Grade
			✓ if Transfer	Initials	Date		
<i>Engineering Fundamentals (3 courses required)</i>							
CS	106A	Programming Methodology (req'd)				5	
ENGR		25 or 40 (req'd)					
ENGR							
<i>Engineering Fundamentals Unit Total</i>							

### Engineering Depth (7 courses required; no course may be listed more than once; no double-counting)

		CS 103, 106B/X, or CME 108 (req'd)					
ENGR	60	Engineering Economy (req'd)				3	
MS&E	108	Senior Project (req'd)				5	
MS&E	111	Intro to Optimization (req'd)				4	
MS&E		130 or 134 (req'd)					
MS&E		142 or 260 (req'd)					
MS&E	180	Organizations (req'd)				4	

### Engineering Depth Concentration (7-8 courses required; see note 3)

Circle one concentration:    F&DE    OR    OTE    POM    T&P							
<i>Engineering Unit Total</i>							

### Program Totals

<i>Mathematics and Science (45 units minimum)</i>	
<i>Engineering Fundamentals and Engineering Depth (between 60 and 72 units)</i>	

### Program Approvals

#### Advisor/Student Services

Advisor Name: \_\_\_\_\_ Date: \_\_\_\_\_  
 Signature: \_\_\_\_\_

#### Departmental

Printed Name: \_\_\_\_\_ Date: \_\_\_\_\_  
 Signature: \_\_\_\_\_

#### School of Engineering (signature not required prior to graduation)

Printed Name: \_\_\_\_\_ Date: \_\_\_\_\_  
 Signature: \_\_\_\_\_

### NOTES (continued from page 1)

- (3) The "Writing in the Major" requirement will normally be fulfilled through a course taken in the concentration or for the Technology in Society requirement.