

ENVIRONMENTAL ENGINEERING

— ABET ACCREDITATION CRITERIA APPLY —

The environmental engineering profession works to protect and manage our air, water, and energy resources. Environmental engineers quantitatively analyze the environmental changes that inevitably result from human activities, designing strategies to remediate problems, minimize impacts, and measurably improve environmental quality.

The environmental engineering field is refreshingly multi-disciplinary in nature, combining fundamental principles drawn from physics, chemistry, geology and biology with analytical methods. Practitioners focus on developing devices, techniques and solutions that can effectively address a variety of real-world environmental problems.

OBJECTIVES AND OUTCOMES FOR ENVIRONMENTAL ENGINEERING

Objectives:

1. *Principles and Skills:* Provide an understanding of engineering principles along with analytical, problem-solving, design, and communication skills to continue succeeding and learning in diverse careers.
2. *Preparation for Practice:* Prepare for successful engineering practice with a longer-term perspective that takes into account new tools, such as advanced information technology and biotechnology, and increasingly complex professional and societal expectations.
3. *Preparation for Graduate Study:* Prepare for possible graduate study in engineering or other fields.
4. *Preparation for Service:* Develop the awareness, background, and skills to become responsible citizens and leaders in service to society.

Outcomes:

- (a) A proficiency in and ability to apply knowledge of engineering, mathematics through differential equations, probability and statistics, and science including physics and chemistry
- (b) An ability to design and conduct experiments, as well as to analyze and interpret data
- (c) An ability to design a system, component, or process to meet desired needs
- (d) An ability to function on multi-disciplinary teams
- (e) An ability to identify, formulate, and solve engineering problems
- (f) An understanding of professional and ethical responsibility
- (g) An ability to communicate effectively
- (h) The broad education necessary to understand the impact of engineering solutions in a global and societal context
- (i) A recognition of the need for, and an ability to engage in, life-long learning
- (j) A knowledge of contemporary issues
- (k) An ability to use the techniques, skills, and modern engineering tools necessary for engineering practice.
- (l) Background for admission to engineering or other professional graduate programs

THE CURRICULUM

The undergraduate environmental engineering curriculum consists of a set of core classes considered essential for the major, along with additional classes students can select from a list of breadth electives. This major was added to Stanford's undergraduate curriculum in 2000 and became an ABET-accredited environmental engineering degree in 2004.

Those undergraduates potentially interested in the Environmental Engineering major may want to examine the *Environmental and Water Studies* specialization of the Civil Engineering major as a possible alternative; a comparison of these two majors is presented below.

For more information on environmental engineering, please contact Sandra Wetzel in Room 316 of the Jerry Yang and Akiko Yamazaki Environment & Energy (Y2E2) building.

RESEARCH EXPERIENCE FOR UNDERGRADUATES

The department of Civil and Environmental Engineering welcomes student participation in the VPUE undergraduate research programs. Interested students should check the VPUE website (<http://www.stanford.edu/dept/undergrad/vpue/>) and the CEE website (<http://cee.stanford.edu/>) for announcements regarding the application procedures. Annual program announcements typically appear in December and January with application due dates in February.

A COMPARISON: ENVIRONMENTAL ENGINEERING VS. CIVIL ENGINEERING

Those students interested in environmental studies should be aware of the differences between choosing the Environmental Engineering major and the *Environmental and Water Studies* specialization of the Civil Engineering major. Noteworthy considerations include:

1. *Curricular Differences:* The Civil Engineering (CE) major requires ENGR 14 (Applied Mechanics), CEE101A (Mechanics of Materials), and CEE101C (Geotechnical Engineering), while the Environmental Engineering (EnvE) major does not. This is because these classes are essential background for the structures/construction area of Civil Engineering. The EnvE major lists CEE 64 (Air Pollution) as a required class (while CE does not) and offers 10 of Breadth electives (vs. 6 units for CE).

2. *Professional Considerations:* Both the CE and EnvE degrees are ABET-accredited, which is a first step toward a professional engineering license. The EnvE degree was accredited by ABET in 2004.
3. *Philosophical Considerations:* Some faculty and students feel that "Civil Engineering" implies a broader background, and may thus lead to a broader range of job opportunities. But others argue that "Environmental Engineering" is a more accurate description for a course of study that emphasizes the environment. And finally, there are others who feel that the name itself makes little or no difference.

EXPLORING ENVIRONMENTAL ENGINEERING AS A MAJOR

Attention, freshmen and sophomores: Are you thinking about an engineering major, or wondering whether an Environmental Engineering major is for you? If so, here is some advice on courses accessible early in your undergraduate career that will help you assess your interest in our major. If you end up joining our program, this early start on fulfilling requirements will pay off by giving you more flexibility in class scheduling for your junior and senior years.

1. For an introduction to Environmental Engineering, classes required for all of our declared majors which are readily accessible to you are:
CEE 70: Environmental Science & Technology (S)
CEE100: Managing Civil Engineering Projects (WIM)(A)
2. For electives providing additional exposure to the Environmental Engineering major, try:
CEE 63: Weather and Storms (A)
CEE 64: Air Pollution: from Urban Smog to Global Change (S)
CEE173A: Energy Resources (A)
3. For any Engineering major, three Engineering Fundamentals must be taken. Early on, you should consider taking:
ENGR 30: Engineering Thermodynamics (A,W; a req'd fundamental for EnvE)
ENGR 60: Engineering Economy (A,W, Sum; a req'd fundamental for EnvE)
4. You should make sure you take the following Science/Math classes, which are required for almost all majors within the School of Engineering:
CHEM 31A/B or 31X: Chemical Principles (A, W)
PHYSICS 41: Mechanics (W) or 5 units of AP Physics C [co-requisite: MATH 41]
MATH 51: Linear Algebra & Differential Calculus (A,W,S,Sum) or CME 100 [prerequisite: MATH 21, 42]
5. Finally, there are additional Science/Math classes required for students majoring in Environmental Engineering which can readily be taken early on:
GES 1: Fundamentals of Earth Science (A,S)
STATS 110 (or STATS 60 or GES 160): Statistics (A,W,S)

REQUIREMENTS: 2008-09 MAJOR IN ENVIRONMENTAL ENGINEERING

MATHEMATICS AND SCIENCE (45 UNITS MINIMUM), INCLUDING:

Course	Title	Units	Qtr.
Math 41/42	Calculus (or 10 units AP Calculus)	10	A/A,W
CME 100 & 102	Math/Computational Methods for Engineers (or Math 51 & 53)	10	A,W
PHYSICS 41	Mechanics	4	W
CHEM 31*	Chemical Principles (see note 1)	4	A,W,Sum
CHEM 33	Structure and Reactivity (organic chemistry) (see note 2)	4	W,S,Sum
GES 1	Fundamentals of Earth Science	4	A,S
STATS 110	Statistical Methods (or STATS 60 or GES 160 or ENGR 155C)	4-5	A,W,S

(1) CHEM 31B or 31X is required.

(2) CHEM 35 or 135 are also recommended for those students planning to continue on to graduate school, particularly for those who take CHEM 31X.

Engineering Fundamentals (Three courses minimum, the two listed below and one other of student's choice):

ENGR 30	Engineering Thermodynamics	3	A,W
ENGR 60	Engineering Economy	3	A,W, Sum

Technology in Society: *One 3-5 unit course*

See the Figure 3-3 of this handbook for an approved list of courses that fulfill the TIS requirement for Environmental Engineering majors.

Experimentation: *8 units required*

At least 6 units will be earned by fulfilling the Depth requirements below, and 1 unit from GES

1. See the chart on the next page for a list of applicable experimentation units.

Environmental Engineering Depth: (Fundamentals + Depth = 68 Units Minimum)

At least 68 units of Engineering Science plus Engineering Design is required by ABET and by the Department.

Note: The sum of Science and Design units assigned to a course do not always equal the course unit total. Thus, more than 68 units of engineering courses may be needed to satisfy this requirement -- see chart on the next page for Science, Design, and Experimentation units assigned to each course.

REQUIRED CORE: (47 UNITS)

Course	Title	Units	Qtr.
CEE 64*	Air Pollution: Urban Smog to Global Change	3	S
CEE 70	Environmental Science and Technology	3	S
CEE 100	Managing Civil Engineering Projects (<i>meets WIM requirement</i>)	4	A

CEE 101B	Mechanics of Fluids	4	S
CEE 101D*	Computations in CEE	3	A
CEE 160	Mechanics of Fluids Laboratory	2	S
CEE 161A	Rivers, Streams and Canals	4	A
CEE 166A	Watersheds and Wetlands	3	A
CEE 166B	Floods and Droughts, Dams and Aqueducts	3	W
CEE 171	Environmental Planning Methods	3	W
CEE 172	Air Quality Management	3	W
CEE 177	Aquatic Chemistry and Biology	4	A
CEE 179A	Water Chemistry Laboratory	3	W
<i>Design Experience: Choose CEE16 or, CEE179B or CEE 179C</i>		5	S

*Can count either towards the Math or Science requirement, or as engineering units.

BREADTH COURSES: (AT LEAST 10 ADDITIONAL UNITS FROM THE FOLLOWING LIST)

Course	Title	Units	Qtr.
CEE 63*	Weather and Storms	3	A
CEE 101C	Geotechnical Engineering (includes lab)	4	A
CEE 164	Introduction to Physical Oceanography	4	W
CEE 165D	Water and Sanitation in Developing Countries	3	S
CEE 166D	Water Resources and Water Hazards Field Trips	2	W
CEE 169	Environmental and Water Resource Engineering (<i>alternate years</i>)	5	S
CEE 172A	Indoor Air Quality (<i>alternate years</i>)	2-3	S
CEE 173A	Energy Resources (<i>alternate years</i>)	4-5	W
CEE 176A	Energy Efficient Buildings (<i>alternate years</i>)	4	W
CEE 176B	Electric Power: Renewables and Efficiency (<i>alternate years</i>)	4	S
CEE 178	Introduction to Human Exposure Analysis	3	S
CEE 179B	Process Design for Environ. Biotechnology (<i>alternate years</i>)	5	S
CEE 179C	Environmental Engineering Design	5	S
CEE 199	Undergrad Research in Civil & Env. Engineering	1-4	Any

*Can count either towards the Math or Science requirement, or as engineering units.

Other Elective Courses:

Choose additional courses from within the School of Engineering to reach a total of 68 units of Engineering Science+Design. Depending on which Engineering Fundamentals and Breadth classes are taken, up to 9 additional units may be required. Students may need up to 1 more experimentation unit. **Total Engineering Science and Engineering Design units (columns 1 and 2 in the table below) from Fundamentals and Core (required courses and electives) combined must total at least 68 units in order to satisfy ABET requirements to graduate.**

Engineering Science, Engineering Design, and Experimentation Units

SCHOOL OF ENGINEERING COURSES

Course	Title	Engr Sci	Engr Dsgn	Expr	Total
ENGR 10	Introduction to Engineering Analysis	4	-	-	4
ENGR 14	Applied Mechanics: Statics	2	1	-	3
ENGR 15	Dynamics	2	1	-	3
ENGR 20	Introduction to Chemical Engineering	2	1	-	3
ENGR 30	Engineering Thermodynamics	3	-	-	3
ENGR 40	Introductory Electronics	3	2	2	5

ENGR 50	Introductory Science of Materials	4	-	-	4
ENGR 60	Engineering Economy	3	-	-	3
ENGR 70A	Programming Methodology	3	2	-	5

DEPARTMENT OF CIVIL AND ENVIRONMENTAL ENGINEERING COURSES

COURSE	TITLE	ENGR SCI	ENGR DSGN	EXPR	TOTAL
CEE 31Q	Accessing Architecture through Drawing	1	3	-	4
CEE 46Q	Fail Your Way to Success	2	1	-	3
CEE 48Q	Designing Orgs to Execute Global Projects	2	2	-	4
CEE 63	Weather & Storms	3	0	-	3
CEE 64	Air Pollution: Urban Smog to Global Change	3	0	-	3
CEE 70	Environmental Science & Technology	2	1	-	3
CEE 80N	Art of Struct Eng (formerly Form is Function)	2	2	-	4
CEE 100	Managing Sustainable Building Projects	2.5	1.5	1	4
CEE 101A	Mechanics of Materials	3	1	1	4
CEE 101B	Mechanics of Fluids	3	1	-	4
CEE 101C	Geotechnical Engineering	2.5-3	0.5-1	0-1	3-4
CEE 101D	Computations in CEE	2	1	-	3
CEE 102	Legal Aspects of Engineering and Construction	2	1	-	3
CEE 111	Multidisciplinary Modeling and Analysis	1	2	-	3
CEE 115	Goals & Methods for Sustainable Build. Projects	2	1-2	-	3-4
CEE122A/B	Computer Integrated A/E/C	0	2	-	2
CEE 130	Arch. Design: 3D Modeling, Method., & Process	1	3	-	4
CEE 131A	Introduction to the Design Professions	0	2	-	2
CEE 134B	Architectural Studio: Special Topic	2	2	-	4
CEE 135A	Parametric Design	2	2	-	4
CEE 137B	Intermediate Architecture Studio	0	5	-	5
CEE 138A	Contemporary Architecture:	-	3	-	3
CEE 139	Design Portfolio Methods	0	0	-	2
CEE 140	Field Surveying Laboratory	0	3	3	3
CEE 142A	Creating Sustainable Development	2	1	-	3
CEE 147	Cases in Personality, Leadership & Negot.	3	0	1	3
CEE 151	Negotiation	3	0	-	3
CEE 154	Cases in Estimating Cost	1	1	1	3
CEE 156	Building Systems Design	1.5	2.5	-	4
CEE 159	Career Skills Seminar	2	-	-	2
CEE 160	Mechanics of Fluids Laboratory	1	1	2	2
CEE 161A	Rivers, Streams and Canals (for 3 units)	1.5	1.5	-	3
CEE 161A	Rivers, Streams and Canals (for 4 units)	2	2	1	4
CEE 164	Intro to Physical Oceanography	4	0	-	4
CEE 165D	Water and Sanitation in Developing Countries	2	1	-	3
CEE 166A	Watersheds and Wetlands	2	1	-	3
CEE 166B	Floods & Droughts, Dams & Aqueducts	2	1	-	3
CEE 166D	Water Resc. and Water Hazards Field Trips	1	1	-	2
CEE 169	Environmental & Water Resources: Design	0	5	-	5
CEE 171	Environmental Planning Methods	2	1	-	3
CEE 172	Air Quality Management	2	1	-	3
CEE 172A	Indoor Air Quality	1-2	1	-	2-3
CEE 173A	Energy Resources	4-5	0	-	4-5

Course	Title	Engr Sci	Engr Dsgn	Expr	Total
CEE 175A	CA Coast: Science, Policy, and Law	1	0	-	3-4
CEE 176A	Energy Efficient Buildings	2	1-2	0-1	3-4
CEE 176B	Electric Power: Renewables and Efficiency	2	1-2	0-1	3-4
CEE 177	Aquatic Chemistry and Biology	3	1	-	4
CEE 178	Introduction to Human Exposure Analysis	2	1	1	3
CEE 179A	Water Chemistry Laboratory	3	0	3	3
CEE 179B	Process Design for Environ. Biotechnology	2	3	3	5
CEE 180	Structural Analysis	3	1	-	4
CEE 181	Design of Steel Structures	0	4	-	4
CEE 182	Design of Reinforced Concrete Structures	0	4	-	4
CEE 183	Integrated Building Design	0	4	-	4
CEE 190	Near Surface Geophysics	2	1	-	3
CEE 195A/B	Structural Geology & Rock Mechanics	2	1	1	3
CEE 196	Engineering Geology Practice	2	1	-	3
CEE 199	Undergraduate Research in CEE	varies	varies	0-4	1-4

Environmental Engineering

Typical Sequence of Courses

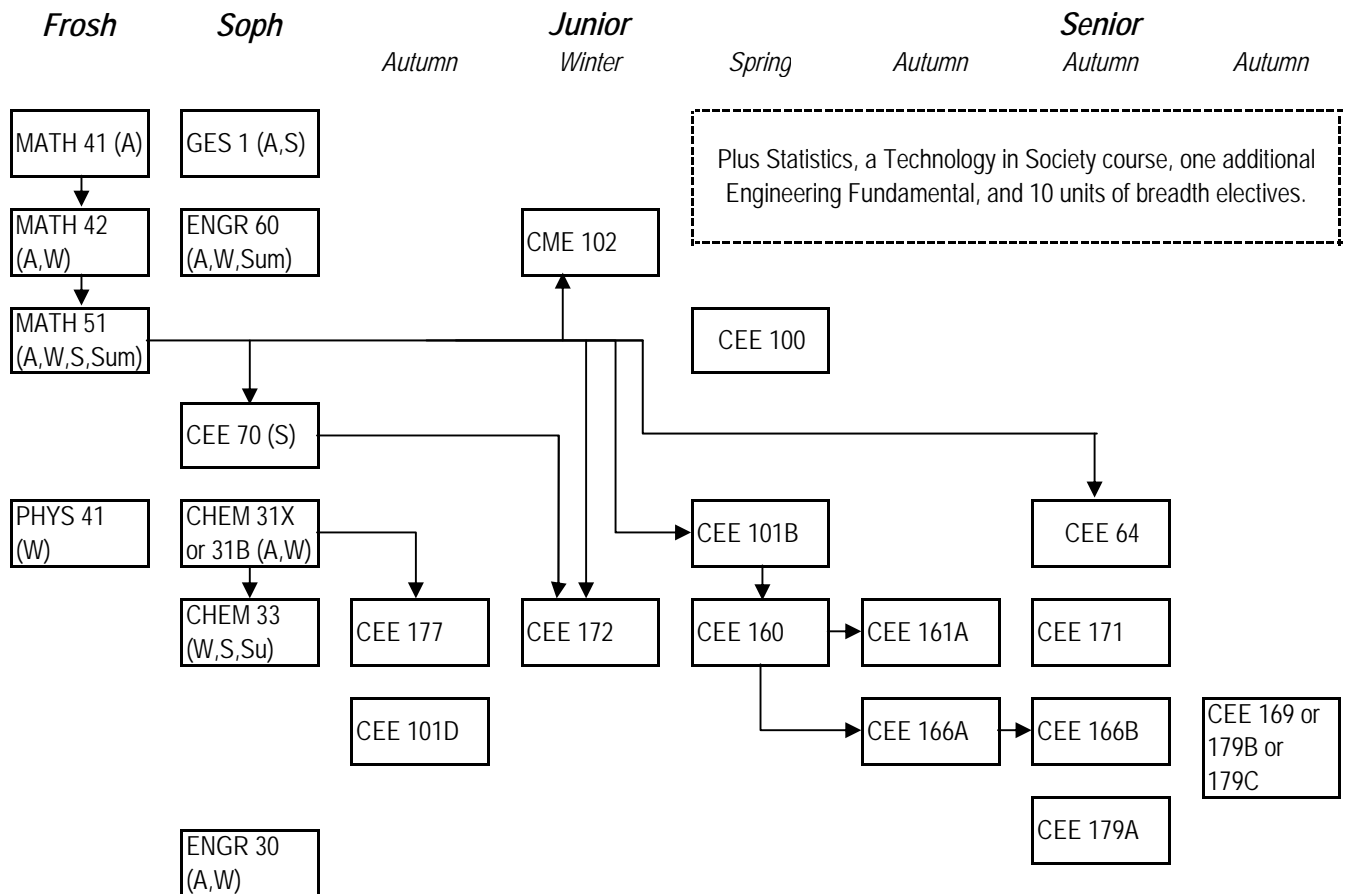

* Arrows represent direct prerequisites

* Dashed-line boxes enclose alternates. These may indicate alternate years in which to take a given course, and/or alternate courses that may be taken at a given time.

Environmental Engineering

Early Start Program

	<i>Fall</i>			<i>Winter</i>			<i>Spring</i>					
	Math/ Class	Sci.	Engr	Other	Math/ Class	Sci.	Engr	Other	Math/ Class	Sci.	Engr	Other
<i>Freshman</i>	MATH 41	5	-	-	MATH 42	5	-	-	Writing	-	-	3
	IHUM	-	-	5	IHUM	-	-	5	IHUM	-	-	5
	CHEM 31A	4	-	-	CHEM 31B	4	-	-	CHEM 33	4	-	-
	Unrstr Elctv [^]	-	-	2	Unrstr Elctv [^]	-	-	2	Engr Elctv+	-	3	-
	<i>Subtotals</i>	<i>9</i>	<i>0</i>	<i>7</i>	<i>Subtotals</i>	<i>9</i>	<i>0</i>	<i>7</i>	<i>Subtotals</i>	<i>4</i>	<i>3</i>	<i>8</i>
Total	16			Total	16			Total	15			
<i>Sophomore</i>	Language	-	-	5	Language	-	-	5	Language	-	-	5
	CEE 101D	-	3	-	CEE 172*	-	3	-	Writing	-	-	3
	CME 100++	5	-	-	CME 102++	5	-	-	Engr Fund	-	3	-
	GER	-	-	4	PHYSICS 41	4	-	-	CEE 70	-	3	-
	<i>Subtotals</i>	<i>5</i>	<i>3</i>	<i>9</i>	<i>Subtotals</i>	<i>9</i>	<i>3</i>	<i>5</i>	<i>Subtotals</i>	<i>0</i>	<i>6</i>	<i>8</i>
Total	17			Total	17			Total	14			
<i>Junior</i>	ENGR 60	-	3	-	ENGR 30*	-	3	-	CEE 101B*	-	4	-
	CEE177	-	4	-	CEE 64	-	3	-	CEE 160	-	2	-
	STAT 60	5	-	-	EnvE Depth	-	4	-	CEE 100	-	4	-
	GES 1	4	-	-	GER	-	-	4	TIS Course	-	-	4
	<i>Subtotals</i>	<i>9</i>	<i>7</i>	<i>0</i>	<i>Subtotals</i>	<i>0</i>	<i>10</i>	<i>4</i>	<i>Subtotals</i>	<i>0</i>	<i>10</i>	<i>4</i>
Total	16			Total	14			Total	14			
<i>Senior</i>	CEE166A	-	3	-	CEE166B	-	3	-	CEE 169**	-	5	-
	CEE161A*	-	4	-	CEE 171	-	3	-	EnvE Depth	-	3	-
	EnvE Depth	-	3	-	CEE 179A	-	3	-	GER	-	-	5
	GER	-	-	4	GER	-	-	5				
	<i>Subtotals</i>	<i>0</i>	<i>10</i>	<i>4</i>	<i>Subtotals</i>	<i>0</i>	<i>9</i>	<i>5</i>	<i>Subtotals</i>	<i>0</i>	<i>8</i>	<i>5</i>
Total	14			Total	14			Total	13			

Total Math & Science Units: 45
 Total Engineering Units: 69
 Total Other Units: 66
Total Units: 180

Notes:

- [^] Students should explore majors of interest to them using these unrestricted electives. Courses in the School of Engineering can count towards the EnvE major; see description of "Other Elective Courses" for details.
- * These classes all are typically offered MWF 10AM.
- ** In alternate years, when CEE169 is not offered, take CEE179B or C in the spring to fulfill design experience.
- + Enough coursework from within the School of Engineering is needed to reach a total of 68 Engineering Science+Engineering Design Units; see description of "Other Elective Courses" for details.
- ++ Can take Math 51 and 53 instead of CME 100 and 102, if desired.

Environmental Engineering

Regular Program

	<i>Fall</i>			<i>Winter</i>			<i>Spring</i>					
	Math/ Sci.	Engr	Other	Class	Math/ Sci.	Engr	Other	Class	Math/ Sci.	Engr	Other	
<i>Freshman</i>	MATH 41	5	-	-	MATH 42	5	-	-	STAT 60	5	-	-
	IHUM	-	-	5	IHUM	-	-	5	IHUM	-	-	5
	Writing	-	-	3	PHYSICS 41	4	-	-	Unrstr Elctv [^]	-	-	3
	GER	-	-	4	Unrstr Elctv [^]	-	-	3	GER	-	-	4
	<i>Subtotals</i>	<i>5</i>	<i>0</i>	<i>12</i>	<i>Subtotals</i>	<i>9</i>	<i>0</i>	<i>8</i>	<i>Subtotals</i>	<i>5</i>	<i>0</i>	<i>12</i>
Total	17			Total	17			Total	17			
<i>Sophomore</i>	Language	-	-	5	Language	-	-	5	Language	-	-	5
	CHEM 31A	4	-	-	CHEM 31B	4	-	-	CHEM 33	4	-	-
	MATH 51++	5	-	-	MATH 53++	5	-	-	CEE 70	-	3	-
	Writing	-	-	3	Engr Fund	-	3	-	Engr Elctv+	-	3	-
	<i>Subtotals</i>	<i>9</i>	<i>0</i>	<i>8</i>	<i>Subtotals</i>	<i>9</i>	<i>3</i>	<i>5</i>	<i>Subtotals</i>	<i>4</i>	<i>6</i>	<i>5</i>
Total	17			Total	17			Total	15			
<i>Junior</i>	ENGR 30 ⁺	-	3	-	EnvE Depth	-	4	-	CEE 101B ⁺	-	4	-
	CEE 177	-	4	-	CEE 172 [*]	-	3	-	CEE 160	-	2	-
	GES 1	4	-	-	CEE 171	-	3	-	CEE 100	-	4	-
	CEE 101D	-	3	-	GER	-	-	4	GER	-	-	4
	<i>Subtotals</i>	<i>4</i>	<i>10</i>	<i>0</i>	<i>Subtotals</i>	<i>0</i>	<i>10</i>	<i>4</i>	<i>Subtotals</i>	<i>0</i>	<i>10</i>	<i>4</i>
Total	14			Total	14			Total	14			
<i>Senior</i>	ENGR 60	-	3	-	CEE 166B	-	3	-	CEE 169 ^{**}	-	5	-
	EnvE Depth	-	3	-	CEE 64	-	3	-	TIS Course	-	-	4
	CEE 161A [*]	-	4	-	CEE 179A	-	3	-	EnvE Depth	-	3	-
	CEE 166A	-	3	-	GER	-	-	4				
	<i>Subtotals</i>	<i>0</i>	<i>13</i>	<i>0</i>	<i>Subtotals</i>	<i>0</i>	<i>9</i>	<i>4</i>	<i>Subtotals</i>	<i>0</i>	<i>8</i>	<i>4</i>
Total	13			Total	13			Total	12			

Total Math & Science Units: 45
 Total Engineering Units: 69
 Total Other Units: 66
Total Units: 180

Notes:

- [^] Students should explore majors of interest to them using these unrestricted electives. Courses in the School of Engineering can count towards the EnvE major; see description of "Other Elective Courses" for details.
- ^{*} These classes all are typically offered MWF 10AM.
- ^{**} In alternate years, when CEE169 is not offered, take CEE179B or C in the spring to fulfill design experience.
- ⁺ Enough coursework from within the School of Engineering is needed to reach a total of 68 Engineering Science+Engineering Design Units; see description of "Other Elective Courses" for details.
- ⁺⁺ Can take CME 100 and 102 instead of Math 51 and 53, if desired.

Environmental Engineering

Autumn Quarter Junior Year Abroad

	<i>Fall</i>			<i>Winter</i>			<i>Spring</i>					
	Math/ Sci.	Engr	Other	Class	Math/ Sci.	Engr	Other	Class	Math/ Sci.	Engr	Other	
<i>Freshman</i>	MATH 41	5	-	-	MATH 42	5	-	-	MATH 51	5	-	-
	IHUM	-	-	5	IHUM	-	-	5	IHUM	-	-	5
	Writing	-	-	3	PHYSICS 41	4	-	-	Engr Fund	-	3	-
	Unrstr Elctv#	-	-	3	Engr Elctv+ [^]	-	3	-	CEE 70	-	3	-
	<i>Subtotals</i>	<i>5</i>	<i>0</i>	<i>11</i>	<i>Subtotals</i>	<i>9</i>	<i>3</i>	<i>5</i>	<i>Subtotals</i>	<i>5</i>	<i>6</i>	<i>5</i>
Total	16			Total	17			Total	16			
<i>Sophomore</i>	Language	-	-	5	Language	-	-	5	Language	-	-	5
	CHEM 31A	4	-	-	CHEM 31B	4	-	-	CHEM 33	4	-	-
	Writing	-	-	3	ENGR 60	-	3	-	CEE 100	-	4	-
	CEE101D	-	3	-	MATH 53	5	-	-	GES 1	4	-	-
	<i>Subtotals</i>	<i>4</i>	<i>3</i>	<i>8</i>	<i>Subtotals</i>	<i>9</i>	<i>3</i>	<i>5</i>	<i>Subtotals</i>	<i>8</i>	<i>4</i>	<i>5</i>
Total	15			Total	17			Total	17			
<i>Junior</i>	GER [^]	-	-	5	CEE 64	-	3	-	CEE 101B*	-	4	-
	GER [^]	-	-	5	CEE 172*	-	3	-	CEE 160	-	2	-
					CEE 171	-	3	-	STAT 60	5	-	-
	--- Autumn Quarter Abroad ---				EnvE Depth	-	4	-	GER	-	-	4
	<i>Subtotals</i>	<i>0</i>	<i>0</i>	<i>10</i>	<i>Subtotals</i>	<i>0</i>	<i>13</i>	<i>0</i>	<i>Subtotals</i>	<i>5</i>	<i>6</i>	<i>4</i>
Total	10			Total	13			Total	15			
<i>Senior</i>	EnvE Depth	-	3	-	CEE 166B	-	3	-	CEE 169**	-	5	-
	CEE 177	-	4	-	CEE 179A	-	3	-	TIS Course	-	-	4
	CEE 161A*	-	4	-	ENGR 30*	-	3	-	EnvE Depth	-	3	-
	CEE 166A	-	3	-	GER	-	-	5	GER	-	-	4
	<i>Subtotals</i>	<i>0</i>	<i>14</i>	<i>0</i>	<i>Subtotals</i>	<i>0</i>	<i>9</i>	<i>5</i>	<i>Subtotals</i>	<i>0</i>	<i>8</i>	<i>8</i>
Total	14			Total	14			Total	16			

Total Math & Science Units: 45

Total Engineering Units: 69

Total Other Units: 66

Total Units: 180

Notes:

Students should explore majors of interest to them using these unrestricted electives.

* These classes all are typically offered MWF 10AM.

** In alternate years, when CEE169 is not offered, take CEE179B or C in the spring to fulfill design experience.

+ Enough coursework from within the School of Engineering is needed to reach a total of 68 units of Engineering Science + Engineering Design; see description of "Other Elective Courses" for details.

^ Most Overseas programs offer multiple classes that meet the DB-SocSci, DB-Hum, and EC-GlobalCom GERs. Students should save these GERs for the overseas quarter. Some Overseas programs also offer Engr 40 and/or 50.

Environmental Engineering

Winter Quarter Junior Year Abroad

	<i>Fall</i>			<i>Winter</i>			<i>Spring</i>					
	Math/ Sci.	Engr	Other	Class	Math/ Sci.	Engr	Other	Class	Math/ Sci.	Engr	Other	
<i>Freshman</i>	MATH 41	5	-	-	MATH 42	5	-	-	MATH 51	5	-	-
	IHUM	-	-	5	IHUM	-	-	5	IHUM	-	-	5
	Writing	-	-	3	PHYSICS 41	4	-	-	CEE 70	-	3	-
	Unrstr Elctv#	-	-	3	Engr Elctv+^	-	3	-	GER ^	-	-	4
	<i>Subtotals</i>	<i>5</i>	<i>0</i>	<i>11</i>	<i>Subtotals</i>	<i>9</i>	<i>3</i>	<i>5</i>	<i>Subtotals</i>	<i>5</i>	<i>3</i>	<i>9</i>
Total	16			Total	17			Total	17			
<i>Sophomore</i>	Language	-	-	5	Language	-	-	5	Language	-	-	5
	CHEM 31A	4	-	-	CHEM 31B	4	-	-	CHEM 33	4	-	-
	MATH 53	5	-	-	CEE 64	-	3	-	EnvE Depth	-	3	-
	Writing	-	-	3	CEE 172*	-	3	-	Stats 60	5	-	-
	<i>Subtotals</i>	<i>9</i>	<i>0</i>	<i>8</i>	<i>Subtotals</i>	<i>4</i>	<i>6</i>	<i>5</i>	<i>Subtotals</i>	<i>9</i>	<i>3</i>	<i>5</i>
Total	17			Total	15			Total	17			
<i>Junior</i>	ENGR 30*	-	3	-	GER ^	-	-	5	CEE 101B*	-	4	-
	CEE 177	-	4	-	GER ^	-	-	5	CEE 160	-	2	-
	GES 1	4	-	-					CEE 100	-	4	-
	CEE 101D	-	3	-	--- Winter Quarter Abroad ---				TIS Course	-	-	4
	<i>Subtotals</i>	<i>4</i>	<i>10</i>	<i>0</i>	<i>Subtotals</i>	<i>0</i>	<i>0</i>	<i>10</i>	<i>Subtotals</i>	<i>0</i>	<i>10</i>	<i>4</i>
Total	14			Total	10			Total	14			
<i>Senior</i>	ENGR 60	-	3	-	CEE 166B	-	3	-	CEE 169**	-	5	-
	CEE 161A*	-	4	-	CEE 171	-	3	-	Engr Fund	-	3	-
	CEE 166A	-	3	-	CEE179A	-	3	-	EnvE Depth	-	3	-
	EnvE Depth	-	4	-	GER	-	-	5	GER	-	-	4
	<i>Subtotals</i>	<i>0</i>	<i>14</i>	<i>0</i>	<i>Subtotals</i>	<i>0</i>	<i>9</i>	<i>5</i>	<i>Subtotals</i>	<i>0</i>	<i>11</i>	<i>4</i>
Total	14			Total	14			Total	15			

Total Math & Science Units: 45

Total Engineering Units: 69

Total Other Units: 66

Total Units: 180

Notes:

- # Students should explore majors of interest to them using these unrestricted electives.
- * These classes all are typically offered MWF 10AM.
- ** In alternate years, when CEE169 is not offered, take CEE179B or C in the spring to fulfill design experience.
- + Enough coursework from within the School of Engineering is needed to reach a total of 68 Units of Engineering Science + Engineering Design; see description of "Other Elective Courses" for details.
- ^ Most Overseas programs offer multiple classes that meet the DB-SocSci, DB-Hum, and EC-GlobalCom GERs. Students should save these GERs for the overseas quarter. Some Overseas programs also offer Engr 40 and/or 50.

Environmental Engineering

Spring Quarter Junior Year Abroad

	<i>Fall</i>			<i>Winter</i>			<i>Spring</i>					
	Math/ Sci.	Engr	Other	Class	Math/S ci.	Engr	Other	Class	Math/S ci.	Engr	Other	
<i>Freshman</i>	MATH 41	5	-	-	MATH 42	5	-	-	MATH 51	5	-	-
	IHUM	-	-	5	IHUM	-	-	5	IHUM	-	-	5
	Writing	-	-	3	PHYSICS 41	4	-	-	GER ^	-	-	4
	Unrstr Elctv#	-	-	3	Engr Elctv+^	-	3	-	CEE 70	-	3	-
	<i>Subtotals</i>	<i>5</i>	<i>0</i>	<i>11</i>	<i>Subtotals</i>	<i>9</i>	<i>3</i>	<i>5</i>	<i>Subtotals</i>	<i>5</i>	<i>3</i>	<i>9</i>
Total	16			Total	17			Total	17			
<i>Sophomore</i>	Language	-	-	5	Language	-	-	5	Language	-	-	5
	CHEM 31A	4	-	-	CHEM 31B	4	-	-	CHEM 33	4	-	-
	CEE 101D	-	3	-	CEE 64	-	3	-	CEE 101B*	-	4	-
	Writing	-	-	3	MATH 53	5	-	-	CEE 160	-	2	-
	<i>Subtotals</i>	<i>4</i>	<i>3</i>	<i>8</i>	<i>Subtotals</i>	<i>9</i>	<i>3</i>	<i>5</i>	<i>Subtotals</i>	<i>4</i>	<i>6</i>	<i>5</i>
Total	15			Total	17			Total	15			
<i>Junior</i>	ENGR 30*	-	3	-	EnvE Depth	-	4	-	GER ^	-	-	5
	CEE 177	-	4	-	CEE 172*	-	3	-	GER ^	-	-	5
	EnvE Depth	-	3	-	CEE 171	-	3	-				
	GES 1	4	-	-	STAT 60	5	-	-	--- Spring Quarter Abroad ---			
	<i>Subtotals</i>	<i>4</i>	<i>10</i>	<i>0</i>	<i>Subtotals</i>	<i>5</i>	<i>10</i>	<i>0</i>	<i>Subtotals</i>	<i>0</i>	<i>0</i>	<i>10</i>
Total	14			Total	15			Total	10			
<i>Senior</i>	ENGR 60	-	3	-	Engr Fund	-	3	-	CEE 169**	-	5	-
	CEE 161A*	-	4	-	CEE 166B	-	3	-	EnvE Depth	-	3	-
	CEE 166A	-	3	-	CEE 179A	-	3	-	CEE 100	-	4	-
	GER	-	-	4	GER	-	-	5	TIS Course	-	-	4
	<i>Subtotals</i>	<i>0</i>	<i>10</i>	<i>4</i>	<i>Subtotals</i>	<i>0</i>	<i>9</i>	<i>5</i>	<i>Subtotals</i>	<i>0</i>	<i>12</i>	<i>4</i>
Total	14			Total	14			Total	16			

Total Math & Science Units: 45

Total Engineering Units: 69

Total Other Units: 66

Total Units: 180

Notes:

- # Students should explore majors of interest to them using these unrestricted electives.
- * These classes all are typically offered MWF 10AM.
- ** In alternate years, when CEE169 is not offered, take CEE179B or C in the spring to fulfill design experience
- + Enough coursework from within the School of Engineering is needed to reach a total of 68 Units of Engineering Science + Engineering Design; see description of "Other Elective Courses" for details
- ^ Most Overseas programs offer multiple classes that meet the DB-SocSci, DB-Hum, and EC-GlobalCom GERS. Students should save these GERS for the overseas quarter. Some Overseas programs also offer Engr 40 and/or 50

INSTRUCTIONS FOR DECLARING MAJOR IN ENVIRONMENTAL ENGINEERING

1. Enter your major declaration as Environmental Engineering in **Axess**
2. Pick up your academic folder from your freshman/sophomore adviser and print out your Stanford transcript (unofficial is fine) from **Axess**.
3. Download and complete your major **Program Sheet**, which you can obtain from the UGHB website at <http://ughb.stanford.edu/>. Be sure to fill in all courses that you have taken and those which you plan to take. You will have the opportunity to revise this later, so please fill in as many courses as you can.
4. Bring your academic folder, transcript and completed program sheet to the CEE Student Services office in Room 316 of the Jerry Yang and Akiko Yamazaki Environment & Energy [Y2E2] Building and request to have a CEE advisor assigned to you. You may request a specific advisor if you wish. Office hours are 10:00 am to noon and 2:00 to 4:00 pm, Monday through Friday.
5. Meet with your CEE undergraduate advisor and have him/her review and sign your program sheet.
6. Return your signed program sheet to the CEE Student Services Specialist, who upon receiving your signed sheet will approve your major declaration in Axess.
7. You are encouraged to meet with your CEE undergraduate advisor at least once a quarter to review your academic progress. Changes to your program sheet can be made by printing out a revised sheet, obtaining your undergraduate adviser's signature, and returning the approved sheet to the CEE Student Services Office. *NOTE – It is very important to confirm that your program sheet is up to date at least one quarter prior to graduation. Changes to your program may not be accepted within your final quarter.*
8. Other information:
 - Procedures for requesting transfer credits and program deviations are described in detail in at the beginning of Chapter 4: "Policies and Procedures." The relevant forms are in the back of the Handbook in the "Forms" section, or on the UGHB site under the "Petitions" link. The online forms may be filled out electronically. If you are requesting transfer credits or program deviations, you should bring your completed petition form with your transcript to the CEE Student Services office. Attach your program sheet on file in CEE.
 - Check with the CEE Student Services Office to make sure that you are on the CEE UG student email list for important announcements about department events and activities.

Note: The online version of the UGHB is considered the definitive and final version of SoE requirements for each major. Since corrections or updates may have been made after this Handbook went to press in August 2008, download the online EnvE program sheet from ughb.stanford.edu to ensure you are using an accurate major plan.

Environmental Engineering Program Sheet (continued)

Engineering Topics (Engr Science + Engr Design combined must equal 68 units. See note 3)

Dept	Course	Title	Transfer/AP Approval			Unit Total	Grade	ABET Units		
			✓ if Transfer	Initials	Date			Engr Sci	Engr Des	Experiment
Engineering Fundamentals (3 courses required)										
ENGR	30	Engineering Thermodynamics (req'd)				3		3	0	0
ENGR	60	Engineering Economy (req'd)				3		3	0	0
ENGR		<i>Fundamentals Elective</i>								
<i>Engineering Fundamentals Unit Total</i>										

Engineering Depth

CEE	64	Air Pollut'n:Urban Smog/Global Change (req'd)				3		3	0	0
CEE	70	Environ. Science & Technology (req'd)				3		2	1	0
CEE	100	Man'g Sustainable Bldg Proj (req'd) WIM				4		2.5	1.5	1
CEE	101B	Mechanics of Fluids (req'd)				4		3	1	0
CEE	160	Mechanics of Fluids Laboratory (req'd)				2		1	1	2
CEE	161A	Rivers,Streams and Canals (req'd)				4		2	2	1
CEE	166A	Watersheds and Wetlands (req'd)				3		2	1	0
CEE	166B	Floods Droughts, Dams Aqueducts (req'd)				3		2	1	0
CEE	171	Environmental Planning Methods (req'd)				3		2	1	0
CEE	172	Air Quality Management (req'd)				3		2	1	0
CEE	177	Aquatic Chemistry and Biology (req'd)				4		3	1	0
CEE	179A	Water Chemistry Lab (req'd)				3		3	0	3

Program Totals (ABET Requirements)

Mathematics and Science (45 units minimum)
Engineering Topics (Engr Science + Engr Design) (68 units minimum)
Experimentation (8 units minimum)

Program Approvals

Advisor

Printed Name: _____
 Signature: _____

Date: _____

Departmental

Printed Name: _____
 Signature: _____

Date: _____

School of Engineering (signature not required prior to graduation)

Printed Name: _____
 Signature: _____

Date: _____

NOTES (continued from page 1)

- (3) In order to satisfy ABET requirements for graduation, the EnvEng major must take enough courses so that the combined Engineering Science and Design units from Fundamentals and Depth courses add up to a minimum of 68 units. See Unit Allocation list at ughb.stanford.edu to assess the number of assigned Science/Design units for unlisted courses.