

ELECTRICAL ENGINEERING

— ABET ACCREDITATION CRITERIA APPLY —

The mission of the Department of Electrical Engineering is to offer an EE undergraduate program that augments the liberal education expected of all Stanford undergraduates and imparts a basic understanding of electrical engineering built on a foundation of physical science, mathematics, computing, and technology.

Graduates of the undergraduate program should possess knowledge of electrical engineering fundamentals and at least one specialty area. They are expected to have the basic experimental, design, and communication skills to be prepared for continued study at the graduate level or entry level positions that require basic knowledge of electrical engineering, science, and technology.

The educational objectives and student outcomes for the Department of Electrical Engineering are shown in the table on the following page.

The Departmental Requirements for a BS degree in Electrical Engineering include a core set of courses required of every major and a set of specialty areas from which one sequence must be chosen. Each program of study is also expected to include physics as part of science, and calculus, linear algebra, and ordinary differential equations as part of mathematics. The math requirement also includes a course in basic probability and statistics. Specific math and science requirements for EEs are listed below. Other program requirements detailed below include Technology in Society (one course) and one and one half years of Engineering Topics (68 minimum required; also called Engineering Science and Design units), which include Engineering Fundamentals and Depth, which in turn includes a selection of electrical engineering core courses, a specialty sequence, electrical engineering electives, and a design course from an approved list. To be considered electrical engineering courses, courses must either be listed in the Stanford Bulletin as EE courses or as EE “cognate courses” (courses considered by the Department of EE to be programmatically equivalent to EE courses). The design course is intended to culminate the substantial design experience distributed throughout the curriculum. Students are required to pass a writing-intensive course (WIM) within their major (those who double-major will have to take two WIM courses). The WIM course for the Electrical Engineering Major is EE 108A combined with ENGR 102E.

Students are required to have a program planning sheet approved by their advisor and the department prior to the end of the quarter following the quarter they declare their major and at least one year prior to graduation. Programs may be changed at anytime except during the final quarter before graduation by submitting and having approved a new program sheet. Program sheets for the general EE requirements and for each of the EE specialty sequences may be found at <http://ughb.stanford.edu>.

OBJECTIVES AND OUTCOMES FOR ELECTRICAL ENGINEERING

Objectives:

1. *Technical Knowledge:* Provide a basic knowledge of electrical engineering principles along with the required supporting knowledge of mathematics, science, computing, and engineering fundamentals. The program must include depth in at least one specialty area, currently including Computer Hardware, Computer Software, Controls, Circuits and Devices, Fields and Waves, Communication and Signal Processing, and Solid State and Photonic Devices.
2. *Laboratory and Design Skills:* Develop the basic skills needed to perform and design experimental projects. Develop the ability to formulate problems and projects and to plan a process for solutions taking advantage of diverse technical knowledge and skills.
3. *Communications Skills:* Develop the ability to organize and present information, and to write and speak effective English.
4. *Preparation for Further Study:* Provide sufficient breadth and depth for successful subsequent graduate study, post-graduate study, or lifelong learning programs.
5. *Preparation for the Profession:* Provide an appreciation for the broad spectrum of issues arising in professional practice, including teamwork, leadership, safety, ethics, service, economics, and professional organizations.

Outcomes:

- (a) An ability to apply knowledge of mathematics, science, and engineering
- (b) An ability to design and conduct experiments, as well as to analyze and interpret data
- (c) An ability to design a system, component, or process to meet desired needs
- (d) An ability to function on multi-disciplinary teams
- (e) An ability to identify, formulate, and solve engineering problems
- (f) An understanding of professional and ethical responsibility
- (g) An ability to communicate effectively
- (h) The broad education necessary to understand the impact of engineering solutions in a global and societal context
- (i) A recognition of the need for, and an ability to engage in, life-long learning
- (j) A knowledge of contemporary issues
- (k) An ability to use the techniques, skills, and modern engineering tools necessary for engineering practice
- (l) Background for admission to engineering or other professional graduate programs

To place the requirements in context, sample programs of study are given which satisfy all requirements for the BS degree in EE. Students with advanced placement will have greater freedom in course selection than is shown in the program examples. Those considering studying at one of the foreign centers should consult the Overseas Study Office as soon as possible, for this

will add constraints in program planning. All students are expected to consult their faculty advisor, are encouraged to consult the Electrical Engineering Undergraduate Advising Center, and may find it useful to consult other students when designing their program.

For updated information, visit the EE website at: <http://ee.stanford.edu/>

RESEARCH EXPERIENCE FOR UNDERGRADUATES

The Electrical Engineering Department at Stanford University invites undergraduates majoring in EE to participate in its REU Summer Program from June to August. The program is designed to give undergraduates an opportunity to work with members of the EE Faculty and their research groups on advanced research topics.

Program Structure

The program is designed to give both an in-depth research experience on a particular topic, as well as a broad hands-on exposure to various areas within EE.

Bi-weekly seminars are offered to cover a wide range of topics. The seminar series lecturers are comprised of EE faculty and/or guest(s). Discussions will include topics such as graduate education, internships and career opportunities.

Presentations

The last week of the summer program will be devoted to writing a final report and creating a poster on the research project. The students will present their projects at a poster fair, to which the EE Community will be invited.

Funding/Housing

Each student receives a summer stipend. Students are required to reside in undergraduate housing with the Summer Research College. A meal plan is also provided.

Application Procedure

1. Go to <http://eeclass.stanford.edu/reu/>
2. Click on STUDENTS
3. Register
4. Login
5. The application has two steps. You can re-submit both steps at any point up to the deadline. The deadline for students to apply is Feb 23, 2007.

6. If you have any questions about the application, email gradta@stanford.edu
If you have any questions about the logistics of the REU program, email tasha@ee.stanford.edu

REU Requirements

Students must declare EE as their undergraduate major. With the exception of co-terms, in order to be eligible students may not be seniors when they apply. In the event the number of applicants exceeds the number of spaces available, preference is given to first time participants. If you have any questions regarding this information, please contact Natasha Newson, Manager of Academic Programs, in Packard 173 (725-9339, tasha@ee.stanford.edu).

STANFORD UNIVERSITY/ÉCOLE CENTRALE PARIS JUNIOR YEAR ABROAD PROGRAM

Although not formally part of the Overseas Studies Program, Stanford Electrical Engineering undergraduates can receive credit for study abroad at École Centrale Paris. École Centrale Paris is one of the best known science and engineering schools in France and Europe. Stanford students are enrolled in engineering program classes with French and international students. Instruction is mostly in French. For more information, see the “Overseas Studies” section of this handbook and the website <http://www.ecp.fr/study-program/stanford>, or contact Prof. Brad Osgood, Packard 271.

REQUIREMENTS FOR THE MAJOR

Math and Science Requirements:

A minimum of 45 units of mathematics and science combined are required, including the following required courses:

Math: MATH 41, 42, OR (51 AND 52) OR (CME 100 AND CME 104), (53 OR CME 102), (EE178 OR STATS 116 OR MATH 151 OR CME 106)

Science: PHYSICS (41, 43, 45) OR (61, 63, 65)

A minimum of 12 science units is required. Phys 45 is no longer required, but it is strongly recommended for those pursuing the *Fields and Waves* or the *Solid State and Photonic Devices* specialties. Substitutions require approval of the advisor, department, and School.

Technology in Society:

See the “Approved Courses” section of this handbook (Figure 3-3) for courses that fulfill the TIS requirement.

Engineering Topics:

A minimum of 68 units (approximately 1.5 years) of Engineering Topics(Engineering Science and Design units) and minimum 8 units of Experimentation is required by ABET and by the Department. Engineering Topics include both Engineering Fundamentals and Engineering Depth, though the number of Science and Design units assigned to a course do not always equal the course unit total (see table below). Engineering Fundamentals consist of three courses chosen from the School list of approved courses (Figure 3-4), one of which must be E70X and one of which must be outside of EE and CS. Electrical Engineering Depth comprises Core courses, a Specialty Sequence, and Electrical Engineering Electives. In addition to courses taught within the EE department, certain extra-departmental courses designated as EE “cognate courses” are considered to be equivalent to EE courses with respect to all of the degree requirements. A list of approved EE cognate courses is given in a table on the following page. Any extra-departmental course included in the EE core or a specialty sequence may be assumed to be an EE cognate course.

ENGINEERING FUNDAMENTALS:

Programming Methodology	ENGR 70X (CS 106X) or CS 106B
2 from approved list (excluding CS courses, ENGR 40 recommended)	

CORE COURSES REQUIRED OF ALL MAJORS:

Circuits	EE 101A,B
Signal Processing and Linear Systems	EE 102A,B
Digital Systems	EE 108A,B
Technical Writing	ENGR 102E (joint with EE 108A)
Physics in Electrical Engineering	EE 41 or EE 141
The Electrical Engineering Profession	EE 100

THREE COURSES FROM ONE OF THE SPECIALTY AREAS LISTED BELOW:

Computer Hardware	EE 109, CS 107, EE 271, EE 273, EE 282
Computer Software	CS 107, CS 108, CS 194, (EE 284 or CS 244A)
Controls	ENGR 105, ENGR 205 ENGR 206, ENGR 207A, B,, ENGR 209A, B, EE 263
Circuits and Devices	EE 116, EE 122, EE 133, EE 212, EE 214, EE 215, EE 216, EE 271
Fields and Waves	EE 134, EE 141, EE 142, EE 144, EE 241, EE 246, EE 247, EE 252, EE 256
Signal Processing and Communications	EE 133, EE 168, EE 179, EE 261, EE 263, (EE 264 or EE 265),EE 276, EE 278, EE 279
Solid State and Photonic Devices	EE 116, EE 134, EE 136, EE 141, EE 216, EE 222, EE 223, EE 228, EE 235, EE268

Note: EE 141 can be included in the Fields and Waves specialty sequence only if it is not used to fulfill the Physics in EE core requirement.

DESIGN COURSE:

At least one of the following design projects must be included in each program:

EE 109, EE 133, EE 134, EE144, EE 168, CS 194), ENGR 206, EE 256, EE 262, EE 265.

ELECTIVES:

A total of 68 Engineering Topics Units consisting of Engineering Science and Engineering Design units from any graded EE or EE cognate courses, any CS 193 courses, or a maximum of two additional Engineering Fundamentals are required. EE 100 and ENGR 102E do not count toward the 68 units. Up to 10 units of EE 191 (Special Studies with Reports) can count toward the 68 Engineering Topics units (check with the instructor to determine the number of Topics units that can be applied).

ELECTRICAL ENGINEERING COGNATE COURSES :

<i>Course</i>	<i>Course Title</i>	<i>EE Level</i>
AA 272C	Global Positioning Systems	200-299
AA 278	Optimal Control and Hybrid Systems	200-299
APPPHYS 207	Laboratory Electronics	100-199
APPPHYS 208	Laboratory Electronics	100-199
APPPHYS 226	Physics of Quantum Information	200-299
APPPHYS 227	Applications of Quantum Information	200-299
APPPHYS 272	Solid State Physics I	200-299
APPPHYS 273	Solid State Physics II	200-299
CS 107	Programming Paradigms	100-199
CS 108	Object-Oriented Systems Design	100-199
CS 140	Operating Systems and Systems Programming	200-299
CS 143	Compilers	200-299
CS 148	Introductory Computer Graphics	100-199
CS 194	Software Project	100-199
CS 205	Mathematical Methods for Robotics, Vision, and Graphics	200-299
CS 221	Artificial Intelligence: Principles and Techniques	200-299
CS 223B	Introduction to Computer Vision	200-299
CS 228	Probabilistic Models in Artificial Intelligence	200-299
CS 229	Machine Learning	200-299
CS 240	Advanced Topics in Operating Systems	200-299
CS 242	Programming Languages	200-299
CS 244A	Introduction to Computer Networks	200-299
CS 248	Introduction to Computer Graphics	200-299
CS 255	Introduction to Cryptography	200-299
ENGR 105	Feedback Control Design	100-199
ENGR 205	Introduction to Control Design Techniques	200-299
ENGR 206	Control System Design	200-299
ENGR 207A	Modern Control Design I	200-299
ENGR 207B	Modern Control Design II	200-299
ENGR 209A	Analysis and Control of Nonlinear Systems	200-299

ENGR 209B	Advanced Nonlinear Control	200-299
ENGR 210B	Advanced Topics in Computation for Control	200-299
ENGR 240	Introduction to Micro- and Nanofabrication technologies	200-299
GEOPHYS 140	Introduction to Remote Sensing	100-199
MATSCI 209	Electronic and Optical Properties of Solids	200-299
MATSCI 323	Thin Film and Interface Microanalysis	200-299
MATSCI 347	Introduction to Magnetism and Magnetic Nanostructures	200-299
ME 358	Heat Transfer in Microdevices	200-299
MS&E 237	Progress in Worldwide Telecommunications	200-299
MS&E 251	Stochastic Decision Models	200-299
MS&E 246	Game Theory with Engineering Applications	200-299
STATS 315A	Modern Applied Statistics: Learning	200-299
STATS 315B	Modern Applied Statistics: Data Mining	200-299

Total Engineering Topics Units: 68 units

(Fundamental + Core + EE Specialty + Electives)

It is a School of Engineering requirement that all courses counting toward the major must be taken for a letter grade (A,B,C,D,F) if the instructor offers that option. Students with multiple majors should be aware that a depth course cannot be counted toward multiple majors, but the course can be double counted as a secondary major. This may necessitate taking additional courses in the case of double majors, but will have no effect if one is a secondary major.

Sample 4-year plans and flowcharts illustrating ways to fulfill the EE undergraduate major requirements are provided for each of the specialties. These examples are given to assist in planning a complete program. They are only guidelines. In general, however, scheduling is easier if engineering classes are taken as early as possible. Variations that appear in the first two years of the different sample schedules simply illustrate different options available to students before they specialize (except that MATH 113 may be needed for the Controls specialty).

Sample EE undergraduate Program Sheets follow the sample 4-year plans for Electrical Engineering specialties. For updated information and Excel templates, visit the web site at <http://ughb.stanford.edu>.

The following two tables provide the total units, the division of engineering science and engineering design units, and the experimentation units for courses used toward the EE degree. The experimentation units are counted separately and are used only for the ABET Laboratory units requirement.

ENGINEERING SCIENCE, ENGINEERING DESIGN, AND EXPERIMENTATION UNITS

Course	Title	Engr. Sci.	Engr. Dsgn.	Expr.	Total
Fundamentals					
ENGR 70X	Programming Methodology (CS 106X)	4	1	-	5
<i>And one of the following:</i>					
ENGR 40	Introductory Electronics (recommended)	3	2	2	5
ENGR 14	Applied Mechanics: Statics and Deformables <i>or</i>	2	1	-	3
ENGR 15*	Mechanics	2	1	-	3
ENGR 20	Introduction to Chemical Engineering	2	1	-	3
ENGR 30	Engineering Thermodynamics	3	-	-	3
ENGR 50	Introductory Science of Materials	4	-	-	4
ENGR 60	Engineering Economy <i>OR</i>	3	-	-	3
ENGR 62*	Introduction to Optimization	4	-	-	4
Core Courses					
EE 41	Physics of Electrical Engineering <i>or</i>	3	2	2	5
EE 141 *	Engineering Electromagnetics	4	-	-	4
EE 100	The Electrical Engineering Profession	-	-	-	1
EE 101A	Circuits I	4	-	1	4
EE 101B	Circuits II	3	1	1	4
EE 102A	Signal Processing and Linear Systems I	4	-	1	4
EE 102B	Signal Processing and Linear Systems II	4	-	1	4
EE 108A	Digital Systems I	3	1	1	4
EE 108B	Digital Systems II	3	1	1	4
ENGR102E	Technical/Professional Writing for Electrical Engineers	-	-	-	-
Specialty Courses					
<i>Computer Hardware</i>					
CS 107	Programming Paradigms	2	3	-	5
EE 109	Digital Systems Design Laboratory	1	3	4	4
EE 271	Introduction to VLSI systems	1.5	1.5	-	3
EE 273	Digital Systems Engineering	2	1	-	3
EE 282	Computer Architecture and Organization	2	1	-	3
<i>Computer Software</i>					
CS 107	Programming Paradigms	2	3	-	5
CS 108	Object-oriented Systems Design	2	2	-	4
CS 244A	Introduction to Computer Networks	3	-	-	3
EE 284	Introduction to Computer Networks	3	-	-	3
CS 194	Software Project	-	3	-	3
<i>Controls</i>					
ENGR 207A	Modern Control Design I	3	-	-	3
ENGR 207B	Modern Control Design II	3	-	-	3
ENGR 209A	Analysis & Control of Nonlinear Systems	-	3	-	3
ENGR 209B	Advanced Nonlinear Control	3	-	-	3
EE 263	Introduction to Linear Dynamical Systems	2.5	0.5	-	3

(continued on next page)

* "Or" means that only one of the two courses may be used to fulfill an Engineering Fundamental requirement.

Engineering science, engineering design, and experimentation units cont.

Course	Title	Engr. Sci.	Engr. Dsgn.	Expr.	Total
<i>Circuits and Devices</i>					
EE 116	Semiconductor Device Physics	3	-	-	3
EE 122	Analog Lab	1	2	3	3
EE 133	Analog Communications Design Lab	-	3	2	3
EE 212	Integrated Circuit Fabrication Processes	2	1	-	3
EE 214	Analog Integrated Circuit Design	-	3	-	3
EE 215	Bipolar Analog Integrated Circuit Design	-	3	-	3
EE 216	Principles and Models of Semiconductor Devices	3	-	-	3
EE 271	Introduction to VLSI Systems	1.5	1.5	-	3
<i>Fields and Waves</i>					
EE 134	Introduction to Photonics	2	1	3	4
EE 141	Engineering Electromagnetics	4	-	-	4
EE 142	Electromagnetic Waves	2.5	0.5	-	3
EE 144	Wireless Electromagnetic Design Lab	1.5	1.5	1.5	3
EE 241	Waves I	3	-	-	3
EE 246	Microwave Engineering	1.5	1.5	-	3
EE 247	Introduction to Optical Fiber Communications	2	1	-	3
EE 252	Antennas for Telecommunication and Remote Sensing	2	1	-	3
EE 256	Electromagnetics	1	2	-	3
<i>Signal Processing</i>					
EE 133	Analog Communications Design Lab	-	3	2	3
EE 168	Introduction to Digital Image Processing	3	-	-	3
EE 179	Signal Processing and Communication	3	-	-	3
EE 261	Fourier Transform and its Applications	3	-	-	3
EE 263	Introduction to Linear Dynamical Systems	2.5	0.5	-	3
EE 264	Digital Filtering	1.5	1.5	-	3
EE 265	Signal Processing Laboratory	2	2	3	4
EE 276	Introduction to Wireless Personal Communications	2	1	0	3
EE 278	Introduction to Statistical Signal Processing	3	-	-	3
EE 279	Introduction to Communication Systems	3	-	-	3
<i>Solid State and Photonic Devices</i>					
EE 116	Semiconductor Device Physics	3	-	-	3
EE 134	Introduction to Photonics	3	1	2	4
EE 136	Introduction to Nanophotonics and Nanostructures	3	-	-	3
EE 141	Engineering Electromagnetics	4	-	-	4
EE 216	Principles and Models of Semiconductor Devices	3	-	-	3
EE 222	Applied Quantum Mechanics I	3	-	-	3
EE 223	Applied Quantum Mechanics II	3	-	-	3
EE 228	Basic Physics for Solid State Electronics	3	-	-	3
EE 235	Guided Wave Optical Devices	3	-	-	3
EE 268	Introduction to Modern Optics	3	-	-	3
Other Courses					
EE 202	Medical Electronics	2.5	0.5	-	3
CS 193D	C++ and Object Oriented Programming	1.5	1.5	-	3

Electrical Engineering

Typical Sequence of Courses

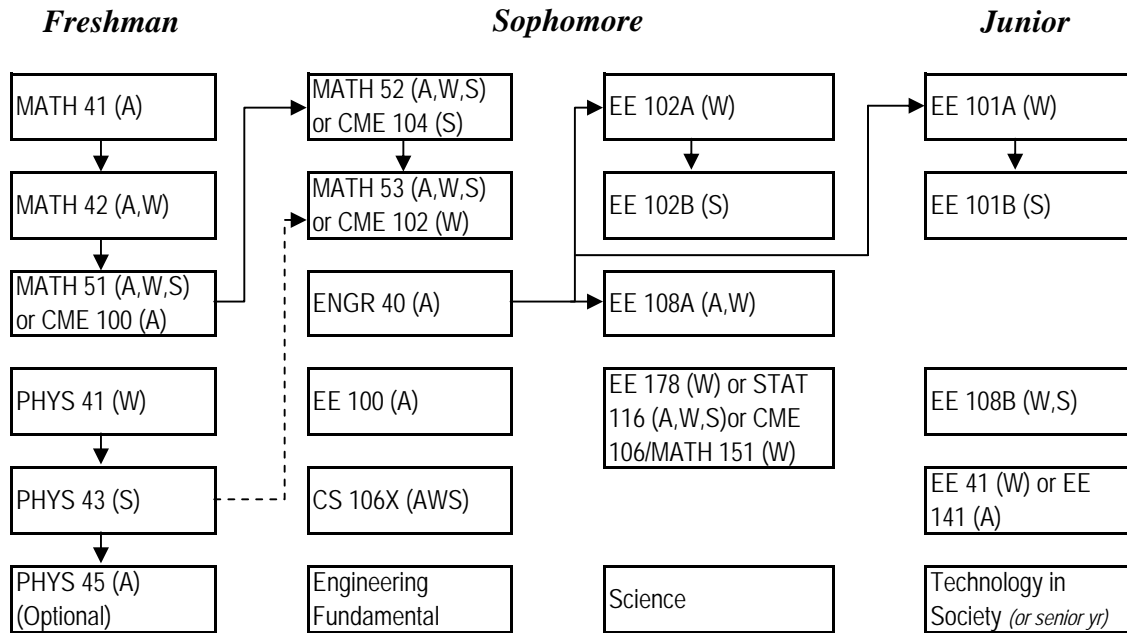

Junior/Senior Year: Choose one track below

Typical courses: see track descriptions for course options

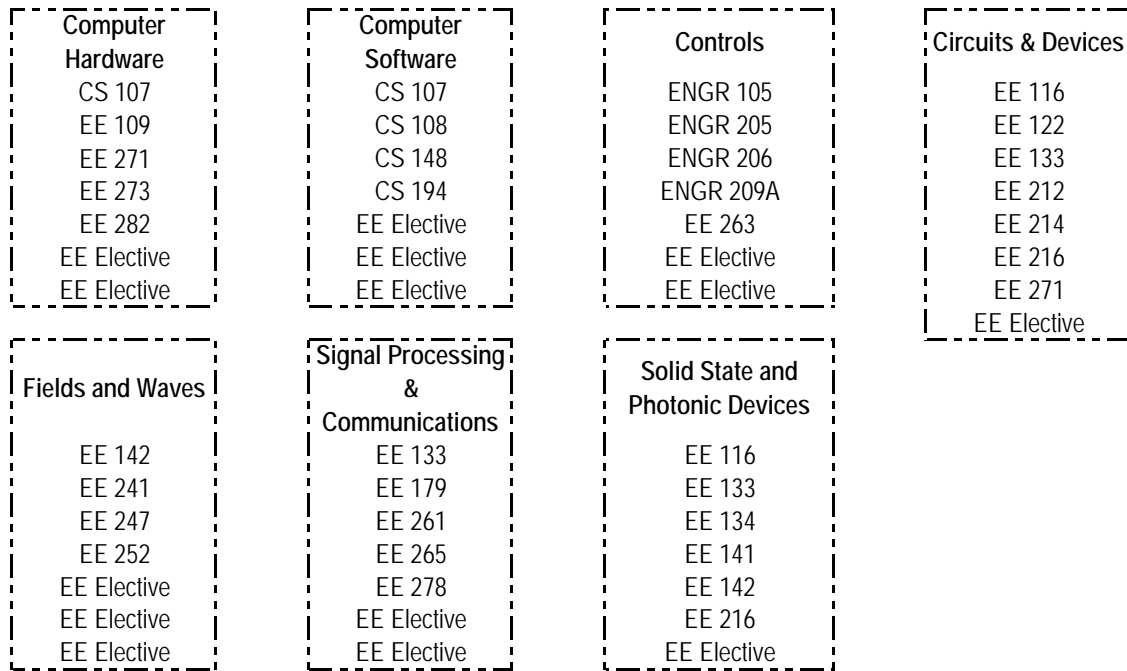

* Arrows represent direct prerequisites; dashed arrows represent recommendations

* Dashed-line boxes indicate alternate courses that may be taken at a given time.

* Typically, students complete 2 out of 3 core sequences (EE101A/B, 108A/B) as sophomores, the third as juniors.

Electrical Engineering

Computer Hardware

	<i>Fall</i>				<i>Winter</i>				<i>Spring</i>			
	Class	Math/ Sci.	Engr.	Other	Class	Math/ Sci.	Engr.	Other	Class	Math/ Sci.	Engr.	Other
<i>Freshman</i>	MATH 41	5	-	-	MATH 42	5	-	-	CME 100	5	-	-
	IHUM	-	-	5	IHUM	-	-	5	IHUM	-	-	5
	Writing	-	-	3	Writing	-	-	3	ENGR 40	-	5	-
	PHYSICS 45	4	-	-	PHYSICS 41	4	-	-	PHYSICS 43	4	-	-
	<i>Subtotals</i>	<i>9</i>	<i>0</i>	<i>8</i>	<i>Subtotals</i>	<i>9</i>	<i>0</i>	<i>8</i>	<i>Subtotals</i>	<i>9</i>	<i>5</i>	<i>5</i>
Total	17			Total	17			Total	19			
<i>Sophomore</i>	EE 100	-	-	1	EE 108B	-	4	-	CS 107	-	5	-
	CS 106A	-	-	5	CME 102	5	-	-	CME 104	5	-	-
	GER	-	-	5	CS 106B	-	5	-	EE 109	-	4	-
	EE 108A	-	4	-								
	ENGR 102E	-	-	1								
<i>Subtotals</i>	<i>0</i>	<i>4</i>	<i>12</i>	<i>Subtotals</i>	<i>5</i>	<i>9</i>	<i>0</i>	<i>Subtotals</i>	<i>5</i>	<i>9</i>	<i>0</i>	
Total	16			Total	14			Total	14			
<i>Junior</i>	EE 122	-	3	-	EE 101A	-	4	-	EE 101B	-	4	-
	EE 281	-	3	-	EE 102A	-	4	-	EE 102B	-	4	-
	CHEM 31A	4	-	-	EE 41	-	5	-	GER	-	-	5
									STATS 116	5	-	-
<i>Subtotals</i>	<i>4</i>	<i>6</i>	<i>0</i>	<i>Subtotals</i>	<i>0</i>	<i>13</i>	<i>0</i>	<i>Subtotals</i>	<i>5</i>	<i>8</i>	<i>5</i>	
Total	10			Total	13			Total	18			
<i>Senior</i>	Language	-	-	5	Language	-	-	5	Language	-	-	5
	EE 271	-	3	-	EE 273	-	3	-	ENGR 50	-	4	-
	EE 282	-	3	-	EE 313	-	3	-	STS	-	-	5
	GER	-	-	5	GER	-	-	5				
	<i>Subtotals</i>	<i>0</i>	<i>6</i>	<i>10</i>	<i>Subtotals</i>	<i>0</i>	<i>6</i>	<i>10</i>	<i>Subtotals</i>	<i>0</i>	<i>4</i>	<i>10</i>
Total	16			Total	16			Total	14			

Total Math & Science Units: 46
 Total Engineering Units: 70
 Total Other Units: 68
Total Units: 184

Electrical Engineering

Computer Software

	<i>Fall</i>			<i>Winter</i>			<i>Spring</i>					
	Math/ Sci.	Engr.	Other	Class	Math/ Sci.	Engr.	Other	Class	Math/ Sci.	Engr.	Other	
<i>Freshman</i>	MATH 41	5	-	-	MATH 42	5	-	-	MATH 51	5	-	-
	IHUM	-	-	5	IHUM	-	-	5	IHUM	-	-	5
	CS 106X	-	5	-	PHYSICS 41	4	-	-	Writing	-	-	3
	PHYSICS 45	4	-	-	EE 12N	-	3	-	PHYSICS 43	4	-	-
	<i>Subtotals</i>	<i>9</i>	<i>5</i>	<i>5</i>	<i>Subtotals</i>	<i>9</i>	<i>3</i>	<i>5</i>	<i>Subtotals</i>	<i>9</i>	<i>0</i>	<i>8</i>
Total	19			Total	17			Total	17			
<i>Sophomore</i>	MATH 52	5	-	-	EE 108A	-	4	-	EE 108B	-	4	-
	CS 107	-	5	-	ENGR 102E	-	-	1	MATH 53	5	-	-
	ENGR 40	-	5	-	Writing	-	-	3	GER	-	-	5
	EE 100	-	-	1	CS 108	-	4	-				
	<i>Subtotals</i>	<i>5</i>	<i>10</i>	<i>1</i>	<i>Subtotals</i>	<i>0</i>	<i>8</i>	<i>4</i>	<i>Subtotals</i>	<i>5</i>	<i>4</i>	<i>5</i>
Total	16			Total	12			Total	14			
<i>Junior</i>	ENGR 60	-	3	-	EE 101A	-	4	-	EE 101B	-	4	-
	STAT 116	5	-	-	EE 102A	-	4	-	EE 102B	-	4	-
	MATH 113	3	-	-	CS 255	-	3	-	GER	-	-	5
					STS 110	-	-	5				
	<i>Subtotals</i>	<i>8</i>	<i>3</i>	<i>0</i>	<i>Subtotals</i>	<i>0</i>	<i>11</i>	<i>5</i>	<i>Subtotals</i>	<i>0</i>	<i>8</i>	<i>5</i>
Total	11			Total	16			Total	13			
<i>Senior</i>	Language	-	-	5	Language	-	-	5	Language	-	-	5
	CS 140	-	4	-	CS 244A	-	4	-	CS 194	-	3	-
	EE 282	-	3	-	EE 41	-	5	-	GER	-	-	5
					EE 261	-	3	-				
	<i>Subtotals</i>	<i>0</i>	<i>7</i>	<i>5</i>	<i>Subtotals</i>	<i>0</i>	<i>12</i>	<i>5</i>	<i>Subtotals</i>	<i>0</i>	<i>3</i>	<i>10</i>
Total	12			Total	17			Total	13			

Total Math & Science Units: 45
 Total Engineering Units: 74
 Total Other Units: 58
Total Units: 177

Electrical Engineering

Controls

	<i>Fall</i>			<i>Winter</i>			<i>Spring</i>					
	Math/ Sci.	Engr.	Other	Class	Math/ Sci.	Engr.	Other	Class	Math/ Sci.	Engr.	Other	
<i>Freshman</i>	MATH 41	5	-	-	MATH 42	5	-	-	MATH 51	5	-	-
	IHUM	-	-	5	IHUM	-	-	5	IHUM	-	-	5
	Writing	-	-	3	Writing	-	-	3	ENGR 40	-	5	-
	PHYSICS 45	4	-	-	PHYSICS 41	4	-	-	PHYSICS 43	4	-	-
	<i>Subtotals</i>	<i>9</i>	<i>0</i>	<i>8</i>	<i>Subtotals</i>	<i>9</i>	<i>0</i>	<i>8</i>	<i>Subtotals</i>	<i>9</i>	<i>5</i>	<i>5</i>
Total	17			Total	17			Total	19			
<i>Sophomore</i>	MATH 52	5	-	-	EE 101A	-	4	-	EE 101B	-	4	-
	CS 106A	-	-	5	EE 102A	-	4	-	EE 102B	-	4	-
	GER	-	-	5	CS 106B	-	5	-	MATH 53	5	-	-
	EE 100	-	-	1					ENGR 62	-	4	-
	<i>Subtotals</i>	<i>5</i>	<i>0</i>	<i>11</i>	<i>Subtotals</i>	<i>3</i>	<i>13</i>	<i>0</i>	<i>Subtotals</i>	<i>5</i>	<i>12</i>	<i>0</i>
Total	16			Total	16			Total	17			
<i>Junior</i>	Math 113	3	-	-	EE 178	3	-	-	MATH 114	3	-	-
	EE 108A	-	4	-	EE 108B	-	4	-	EE 122	-	3	-
	ENGR 105	-	3	-	ENGR 102E	-	-	1	STS 113	-	-	5
	GER	-	-	5	ENGR 206	-	4	-				
	<i>Subtotals</i>	<i>3</i>	<i>7</i>	<i>5</i>	<i>Subtotals</i>	<i>3</i>	<i>8</i>	<i>1</i>	<i>Subtotals</i>	<i>3</i>	<i>3</i>	<i>5</i>
Total	15			Total	12			Total	11			
<i>Senior</i>	Language	-	-	5	Language	-	-	5	Language	-	-	5
	EE 263	-	3	-	EE 209A	-	3	-	EE 278	-	3	-
	ENGR 205	-	3	-	EE 265	-	4	-	GER	-	-	5
	GER	-	-	5	EE 41	-	5	-				
	<i>Subtotals</i>	<i>0</i>	<i>6</i>	<i>10</i>	<i>Subtotals</i>	<i>0</i>	<i>12</i>	<i>5</i>	<i>Subtotals</i>	<i>0</i>	<i>3</i>	<i>10</i>
Total	16			Total	17			Total	13			

Total Math & Science Units: 46
 Total Engineering Units: 69
 Total Other Units: 68
Total Units: 183

Electrical Engineering

Circuits and Devices

	<i>Fall</i>			<i>Winter</i>			<i>Spring</i>					
	Math/ Sci.	Engr.	Other	Class	Math/ Sci.	Engr.	Other	Class	Math/ Sci.	Engr.	Other	
<i>Freshman</i>	MATH 41	5	-	-	MATH 42	5	-	-	MATH 51	5	-	-
	IHUM	-	-	5	IHUM	-	-	5	IHUM	-	-	5
	Writing	-	-	3	Writing	-	-	3	ENGR 40	-	5	-
	PHYSICS 45	4	-	-	PHYSICS 41	4	-	-	PHYSICS 43	4	-	-
	PHYSICS 46	1	-	-								
	<i>Subtotals</i>	<i>10</i>	<i>0</i>	<i>8</i>	<i>Subtotals</i>	<i>9</i>	<i>0</i>	<i>8</i>	<i>Subtotals</i>	<i>9</i>	<i>5</i>	<i>5</i>
	Total	18			Total	17			Total	19		
<i>Sophomore</i>	MATH 52	5	-	-	CS 106B	-	5	-	Math 53	5	-	-
	EE 100	-	-	1	EE 101A	-	4	-	EE 101B	-	4	-
	CS 106A	-	-	5	EE 108B	-	4	-	EE 122	-	3	-
	EE 108A	-	4	-	ENGR 102E	-	-	1				
		<i>Subtotals</i>	<i>5</i>	<i>4</i>	<i>6</i>	<i>Subtotals</i>	<i>0</i>	<i>13</i>	<i>1</i>	<i>Subtotals</i>	<i>5</i>	<i>7</i>
	Total	15			Total	14			Total	12		
<i>Junior</i>					EE 41	-	5	-	EE 102B	-	4	-
	EE 271	-	3	-	EE 102A	-	4	-	GER	-	-	5
	EE 212	-	3	-	EE 178	3	-	-	GER	-	-	5
	EE 114X	-	1	-	ESYS 10	5	-	-	EE 116	-	3	-
		<i>Subtotals</i>	<i>0</i>	<i>7</i>	<i>0</i>	<i>Subtotals</i>	<i>8</i>	<i>9</i>	<i>0</i>	<i>Subtotals</i>	<i>0</i>	<i>7</i>
	Total	7			Total	17			Total	17		
<i>Senior</i>	Language	-	-	5	Language	-	-	5	Language	-	-	5
	EE 214	-	3	-	EE 133	-	3	-	GER	-	-	5
	EE 216	-	3	-	EE 223	-	3	-	ENGR 50	-	4	-
	EE 222	-	3	-	GER	-	-	5	STS 186	-	-	4
		<i>Subtotals</i>	<i>0</i>	<i>9</i>	<i>5</i>	<i>Subtotals</i>	<i>0</i>	<i>6</i>	<i>10</i>	<i>Subtotals</i>	<i>0</i>	<i>4</i>
	Total	14			Total	16			Total	18		

Total Math & Science Units:	46
Total Engineering Units:	71
Total Other Units:	67
Total Units:	184

Electrical Engineering

Fields and Waves

	<i>Fall</i>			<i>Winter</i>			<i>Spring</i>					
	Math/ Sci.	Engr.	Other	Class	Math/ Sci.	Engr.	Other	Class	Math/ Sci.	Engr.	Other	
<i>Freshman</i>	MATH 41	5	-	-	MATH 42	5	-	-	MATH 51	5	-	-
	IHUM	-	-	5	IHUM	-	-	5	IHUM	-	-	5
	Writing	-	-	3	Writing	-	-	3	ENGR 40	-	5	-
	PHYSICS 45	4	-	-	PHYSICS 41	4	-	-	PHYSICS 43	4	-	-
	<i>Subtotals</i>	<i>9</i>	<i>0</i>	<i>8</i>	<i>Subtotals</i>	<i>9</i>	<i>0</i>	<i>8</i>	<i>Subtotals</i>	<i>9</i>	<i>5</i>	<i>5</i>
Total	17			Total	17			Total	19			
<i>Sophomore</i>	EE 100	-	-	1	CS 106B	-	5	-	STATS 116	5	-	-
	MATH 52	5	-	-	MATH 53	5	-	-	EE 144	-	3	-
	EE 141	-	4	-	EE 142	-	3	-	EE 102B	-	4	-
	CS 106A	-	-	5	EE 102A	-	4	-	GER	-	-	5
	<i>Subtotals</i>	<i>5</i>	<i>4</i>	<i>6</i>	<i>Subtotals</i>	<i>5</i>	<i>12</i>	<i>0</i>	<i>Subtotals</i>	<i>5</i>	<i>7</i>	<i>5</i>
Total	15			Total	17			Total	17			
<i>Junior</i>	EE 108A	-	4	-	EE 101A	-	4	-	EE 101B	-	4	-
	EE 241	-	3	-	EE 108B	-	4	-	EE 252	-	3	-
	ENGR 102E	-	-	1	EE 179	-	3	-	ENGR 14	-	3	-
	MATH 113	3	-	-					GER	-	-	5
	<i>Subtotals</i>	<i>3</i>	<i>7</i>	<i>1</i>	<i>Subtotals</i>	<i>0</i>	<i>11</i>	<i>0</i>	<i>Subtotals</i>	<i>0</i>	<i>10</i>	<i>5</i>
Total	11			Total	11			Total	15			
<i>Senior</i>	Language	-	-	5	Language	-	-	5	Language	-	-	5
	EE 247	-	3	-	EE 279	-	3	-	EE 122	-	3	-
	EE 261	-	3	-	MATH 131	3	-	-	GER	-	-	5
	GER	-	-	5	STS 110	-	-	5	EE 278	-	3	-
	<i>Subtotals</i>	<i>0</i>	<i>6</i>	<i>10</i>	<i>Subtotals</i>	<i>3</i>	<i>3</i>	<i>10</i>	<i>Subtotals</i>	<i>0</i>	<i>6</i>	<i>10</i>
Total	16			Total	16			Total	16			

Total Math & Science Units:	48
Total Engineering Units:	71
Total Other Units:	68
Total Units:	187

Electrical Engineering

Signal Processing and Communications

	<i>Fall</i>				<i>Winter</i>				<i>Spring</i>			
	Math/				Math/				Math/			
	Class	Sci.	Engr.	Other	Class	Sci.	Engr.	Other	Class	Sci.	Engr.	Other
<i>Freshman</i>	MATH 41	5	-	-	MATH42	5	-	-	MATH 51	5	-	-
	IHUM	-	-	5	IHUM	-	-	5	IHUM	-	-	5
	Writing	-	-	3	Writing	-	-	3	ENGR 40	-	5	-
	PHYSICS 45	4	-	-	PHYSICS 41	4	-	-	PHYSICS 43	4	-	-
	<i>Subtotals</i>	<i>9</i>	<i>0</i>	<i>8</i>	<i>Subtotals</i>	<i>9</i>	<i>0</i>	<i>8</i>	<i>Subtotals</i>	<i>9</i>	<i>5</i>	<i>5</i>
Total	17			Total	17			Total	19			
<i>Sophomore</i>	EE 100	-	-	1	EE 102A	-	4	-	EE 102B	-	4	-
	MATH 52	5	-	-	EE 178	3	-	-	EE 122	-	3	-
	CS 106A	-	-	5	CS 106B	-	5	-	GER	-	-	5
	MATH 113	3	-	-					MATH 53	5	-	-
	<i>Subtotals</i>	<i>8</i>	<i>0</i>	<i>6</i>	<i>Subtotals</i>	<i>3</i>	<i>9</i>	<i>0</i>	<i>Subtotals</i>	<i>5</i>	<i>7</i>	<i>5</i>
Total	14			Total	12			Total	17			
<i>Junior</i>	EE 108A	-	4	-	EE 101A	-	4	-	EE 101B	-	4	-
	EE 141	-	4	-	EE 108B	-	4	-	EE 278	-	3	-
	ENGR 102E	-	-	1	EE 179	-	3	-	GER	-	-	5
	EE 261	-	3	-	GER	-	-	5				
	GER	-	-	5								
<i>Subtotals</i>	<i>0</i>	<i>11</i>	<i>6</i>	<i>Subtotals</i>	<i>0</i>	<i>11</i>	<i>5</i>	<i>Subtotals</i>	<i>0</i>	<i>7</i>	<i>5</i>	
Total	17			Total	16			Total	12			
<i>Senior</i>	Language	-	-	5	Language	-	-	5	Language	-	-	5
	EE 265	-	3	-	EE 133	-	3	-	EE 276	-	3	-
	EE 263	-	3	-	EE 279	-	3	-	ENGR 62	-	4	-
	STS 110Q	-	-	4	ESYS 10	3	-	-				
	<i>Subtotals</i>	<i>0</i>	<i>6</i>	<i>9</i>	<i>Subtotals</i>	<i>3</i>	<i>6</i>	<i>5</i>	<i>Subtotals</i>	<i>0</i>	<i>7</i>	<i>5</i>
Total	15			Total	14			Total	12			

Total Math & Science Units:	46
Total Engineering Units:	69
Total Other Units:	<u>67</u>
Total Units:	182

Electrical Engineering

Solid State and Photonic Devices

	<i>Fall</i>			<i>Winter</i>			<i>Spring</i>					
	Math/			Math/			Math/					
Class	Sci.	Engr.	Other	Class	Sci.	Engr.	Class	Sci.	Engr. Other			
<i>Freshman</i>	MATH 41	5	-	-	MATH 42	5	-	-	MATH 51	5	-	-
	IHUM	-	-	5	IHUM	-	-	5	IHUM	-	-	5
	Writing	-	-	3	Writing	-	-	3	ENGR 40	-	5	-
	PHYSICS 45	4	-	-	PHYSICS 41	4	-	-	PHYSICS 43	4	-	-
	PHYSICS 46	1	-	-								
	<i>Subtotals</i>	<i>10</i>	<i>0</i>	<i>6</i>	<i>Subtotals</i>	<i>9</i>	<i>0</i>	<i>6</i>	<i>Subtotals</i>	<i>9</i>	<i>5</i>	<i>5</i>
	Total	18		Total	17		Total	19				
<i>Sophomore</i>	EE 100	-	-	1	CS 106B	-	5	-	MATH 53	5	-	-
	MATH 52	5	-	-	STS 110	-	-	5	EE 134	-	4	-
	EE 141	-	4	-	EE 136	-	3	-	EE 101B	-	4	-
	CS 106A	-	-	5	EE 101A	-	4	-				
	<i>Subtotals</i>	<i>5</i>	<i>4</i>	<i>6</i>	<i>Subtotals</i>	<i>0</i>	<i>12</i>	<i>5</i>	<i>Subtotals</i>	<i>5</i>	<i>8</i>	<i>0</i>
	Total	15		Total	17		Total	13				
<i>Junior</i>	GER	-	-	5	EE 102A	-	4	-	EE 102B	-	4	-
	EE 122	-	3	-	MATH 113	3	-	-	EE 116	-	3	-
	EE 108A	-	4	-	EE 108B	-	4	-	STATS 116	5	-	-
	MATH 131	3	-	-	GER	-	-	5	GER	-	-	5
					ENGR 102E	-	-	1				
	<i>Subtotals</i>	<i>3</i>	<i>7</i>	<i>5</i>	<i>Subtotals</i>	<i>3</i>	<i>8</i>	<i>6</i>	<i>Subtotals</i>	<i>5</i>	<i>7</i>	<i>5</i>
	Total	15		Total	17		Total	17				
<i>Senior</i>	Language	-	-	5	Language	-	-	5	Language	-	-	5
	EE 222	-	3	-	EE 223	-	3	-	EE 235	-	3	-
	EE 228	-	3	-	EE 216	-	3	-	GER	-	-	5
	EE 268	-	3	-					ENGR 50	-	4	-
	<i>Subtotals</i>	<i>0</i>	<i>9</i>	<i>5</i>	<i>Subtotals</i>	<i>0</i>	<i>6</i>	<i>5</i>	<i>Subtotals</i>	<i>0</i>	<i>7</i>	<i>10</i>
	Total	14		Total	11		Total	17				

Total Math & Science Units: 49
 Total Engineering Units: 73
 Total Other Units: 68
Total Units: 190

INSTRUCTIONS FOR DECLARING MAJOR IN ELECTRICAL ENGINEERING

Declaring an EE major consists of the following steps:

1. Declare a major in EE on Axess.
2. Fill out a copy of the Undergraduate Sign-Up Sheet, which can be found in the Packard lobby area. The "Specialty" is particularly important to assist in the choice of a faculty advisor. It can always be changed.
3. Meet with the Vice Chair in Packard 176. You can check on office hours by sending email to vicechair@eemail.stanford.edu. In the Vice Chair's absence, see the Director of Student Services in Packard 173. Make sure to bring your Undergraduate Sign-up Sheet, unofficial transcript, and academic file (which you should get from your previous advisor) to the meeting. The purpose of the meeting is to go over the basics in getting a BS in EE, and to assign an EE faculty adviser.
4. After the meeting, leave your academic file and Undergraduate Sign-up Sheet with Diane Shankle in Packard 177, who will certify your Axess declaration within a working day. This completes the formal declaration.
5. It is a good idea to subscribe to both the EE undergrad mailing list and the general EE student mailing list. To do this, send emails to majordomo@lists.stanford.edu with "subscribe ee-undergrad" and "subscribe ee-students" as the messages. These lists are used for announcements about seminars, research opportunities, and other events.

Stanford University ♦ School of Engineering
Electrical Engineering - Required Courses
2006-2007 Sample Program Sheet
— ABET Accreditation Criteria Apply —

Completed and signed program sheet must be submitted to the department before the end of the quarter following the quarter in which the EE major is declared.
Final version of completed and signed program sheet due to the department no later than one month prior to the last quarter of senior year.

Name: _____ SU ID: _____
 Local Address: _____ Local Phone: _____
 _____ Email: _____
 _____ Date B.S. expected: _____

Mathematics and Science Requirement (Delete courses and units not taken)

Dept	Course	Title	Units				Grade	✓ if Transfer	Transfer/AP Approval	
			Engr Sci	Engr Des	Experiment	Total			Initials	Date
<i>Mathematics</i>										
MATH	41	Calculus (req'd)				5				
MATH	42	Calculus (req'd)				5				
MATH	51	Calculus (req'd; see note 1)				5				
MATH	52	Calculus (req'd; see note 1)				5				
MATH	53	Ordinary Differential Eq (req'd; see note 1)				5				
EE	178	Intro Probabilistic Sys Analysis (req'd; see note 1)				3				
<i>Mathematics Unit Total</i>										
<i>Science</i>										
PHYS	41	Mechanics (req'd)				0	4			
PHYS	43	Electricity and Magnetism (req'd)				0	4			
<i>Science Unit Total</i>							<i>(12 units minimum)</i>			
<i>Mathematics and Science Unit Total</i>							<i>(45 units minimum)</i>			

Technology in Society Requirement (1 course required; see UGHB Fig. 3-3 for SoE approved list)

--	--	--	--	--	--	--	--	--	--	--

NOTES

- * Engineering Science, Engineering Design, and Experimentation units do not apply to shaded areas.
 - * This form is available as an Excel file at <http://ughb.stanford.edu>. The printed form must be signed by the advisor and, if required, by the departmental representative. Changes must be initialed in ink. Delete courses not taken.
 - * All courses listed on this form must be taken for a letter grade if offered by the instructor.
 - * Minimum Combined Grade Point Average for all courses in Engineering Topics (Engineering Science and Engineering Design courses) is 2.0.
 - * Transfer and AP credits in Math, Science, Funds., & TIS must be approved by the SoE Dean's Office. Transfer credits in Engineering Depth must be approved by the Advisor. Transfer credit information and petitions are available at <http://ughb.stanford.edu/transfer.html>.
 - * All courses listed on this form must only be included under one category.
- (1) The CME math sequence (CME 100, 102, and 104 or 106) may be substituted for the MATH 51/52/53 sequence; CME 106, STAT 116 or MATH 151 may be substituted for EE178. Other substitutions require approval.

program sheet continues on page 2

Electrical Engineering/General Program Sheet (continued)

Engineering Topics (Engineering Science + Engineering Design; add columns 1 and 2; see Note 4)

Dept	Course	Title	Units				Grade	✓ if Transfer	Transfer/AP Approval	
			Engr Sci	Engr Des	Experiment	Total			Initials	Date
Engineering Fundamentals (3 courses required)										
ENGR	40	Introductory Electronics (recomm'd)	3	2	2	5				
ENGR	70X	Prog Meth and Abst (CS106X) (req'd)	4	1	0	5				
<i>Engineering Fundamentals Unit Total</i>										
Engineering Depth (Delete courses and units not taken)										
EE	100	Electrical Engineering Profession (req'd)	0	0	0	1				
EE	41	Physics of Electrical Eng (req'd) (see note 2)	3	2	2	5				
EE	101A	Circuits I (req'd)	4	0	1	4				
EE	101B	Circuits II (req'd)	3	1	1	4				
EE	102A	Signal Processing and Linear Systems I (req'd)	4	0	1	4				
EE	102B	Signal Processing and Linear Systems II (req'd)	4	0	1	4				
ENGR	102E	Tech/Prof Writing (req'd) (see note 3)	0	0	0	1				
EE	108A	Digital Systems I (req'd) (see note 3)	3	1	1	4				
EE	108B	Digital Systems II (req'd)	3	1	1	4				
<i>Engr Science/Engr Design/Experiment/Depth Unit Totals</i>										

Program Totals (ABET Requirements)

Mathematics and Science		(45 units minimum)
Engineering Topics (Engr Science + Engr Design)		(68 units minimum)
Experimentation		(8 units minimum)

Program Approvals

Advisor

Printed Name: _____
Signature: _____

Date: _____

Departmental

Printed Name: _____
Signature: _____

Date: _____

School of Engineering

Printed Name: _____
Signature: _____

Date: _____

NOTES (continued from page 1)

- (2) May take either EE 41 or EE 141.
- (3) Fulfills the "Writing in the Major" requirement for Freshmen and Transfer students entering Fall 96 or later. ENGR102E and EE108A must be taken concurrently.
- (4) Engr. Science and Design units (columns 1 and 2 combined) from Fundamentals and Depth must equal a minimum of 68 units to satisfy ABET requirements for graduation.

Stanford University ♦ School of Engineering
Electrical Engineering - Computer Hardware
2006-2007 Sample Program Sheet
— ABET Accreditation Criteria Apply —

Completed and signed program sheet must be submitted to the department before the end of the quarter following the quarter in which the EE major is declared.
Final version of completed and signed program sheet due to the department no later than one month prior to the last quarter of senior year.

Name: _____ SU ID: _____
 Local Address: _____ Local Phone: _____
 _____ Email: _____
 _____ Date B.S. expected: _____

Mathematics and Science Requirement (Delete courses and units not taken)

Dept	Course	Title	Units				Grade	✓ if Transfer	Transfer/AP Approval	
			Engr Sci	Engr Des	Experiment	Total			Initials	Date
Mathematics										
MATH	41	Calculus (req'd)				5				
MATH	42	Calculus (req'd)				5				
MATH	51	Calculus (req'd; see note 1)				5				
MATH	52	Calculus (req'd; see note 1)				5				
MATH	53	Ordinary Differential Eq (req'd; see note 1)				5				
STAT	116	Theory of Probability (req'd; see note 1)				5				
<i>Mathematics Unit Total</i>										
Science										
PHYS	41	Mechanics (req'd)			0	4				
PHYS	43	Electricity and Magnetism (req'd)			0	4				
PHYS	45	Optics and Thermodynamics (req'd)			0	4				
CHEM	31	Chemical Principles			0	4				
<i>Science Unit Total</i>						16	<i>(12 units minimum)</i>			
<i>Mathematics and Science Unit Total</i>							<i>(45 units minimum)</i>			

Technology in Society Requirement (1 course required; see UGHB Fig. 3-3 for SoE approved list)

COMM	120	Digital Media in Society				5				
------	-----	--------------------------	--	--	--	---	--	--	--	--

NOTES

- * Engineering Science, Engineering Design, and Experimentation units do not apply to shaded areas.
 - * This form is available as an Excel file at <http://ughb.stanford.edu>. The printed form must be signed by the advisor and, if required, by the departmental representative. Changes must be initialed in ink. Delete courses not taken.
 - * All courses listed on this form must be taken for a letter grade if offered by the instructor.
 - * Minimum Combined Grade Point Average for all courses in Engineering Topics (Engineering Science and Engineering Design courses) is 2.0.
 - * Transfer and AP credits in Math, Science, Funds., & TIS must be approved by the SoE Dean's Office. Transfer credits in Engineering Depth must be approved by the Advisor. Transfer credit information and petitions are available at <http://ughb.stanford.edu/transfer.html>.
 - * All courses listed on this form must only be included under one category.
- (1) The CME math sequence (CME 100, 102, and 104 or 106) may be substituted for the MATH 51/52/53 sequence; CME 106, STAT 116 or MATH 151 may be substituted for EE178. Other substitutions require approval.

program sheet continues on page 2

Electrical Engineering/Computer Hardware Program Sheet (continued)

Engineering Topics (Engineering Science + Engineering Design; add columns 1 and 2. See Note 2)

Dept	Course	Title	Units				Grade	✓ if Transfer	Transfer/AP Approval	
			Engr Sci	Engr Des	Experiment	Total			Initials	Date
Engineering Fundamentals (3 courses required)										
ENGR	40	Introductory Electronics (recomm'd)	3	2	2	5				
ENGR	70X	Prog Meth and Abst (CS106X) (req'd)	4	1	0	5				
ENGR	50	Introductory Science of Materials	4	0	0	4				
<i>Engineering Fundamentals Unit Total</i>						14				
Engineering Depth (Delete courses and units not taken)										
EE	100	Electrical Engineering Profession (req'd)	0	0	0	1				
EE	41	Physics of Electrical Eng (req'd) (see note 3)	3	2	2	5				
EE	101A	Circuits I (req'd)	4	0	1	4				
EE	101B	Circuits II (req'd)	3	1	1	4				
EE	102A	Signal Processing and Linear Systems I (req'd)	4	0	1	4				
EE	102B	Signal Processing and Linear Systems II (req'd)	4	0	1	4				
ENGR	102E	Tech/Prof Writing (req'd) (see note 4)	0	0	0	1				
EE	108A	Digital Systems I (req'd) (see note 4)	3	1	1	4				
EE	108B	Digital Systems II (req'd)	3	1	1	4				
EE	122	Analog Laboratory	1	2	3	3				
CS	107	Programming Paradigms	2	3	0	5				
EE	109	Digital Design Laboratory	1	3	4	4				
EE	212	Integrated Circuit Fabrication Processes	1	2	0	3				
EE	271	Introduction to VLSI	1.5	1.5	0	3				
EE	273	Digital Systems Engineering	2	1	0	3				
EE	282	Computer Architecture and Organization	3	0	0	3				
EE	313	Digital MOS Integrated Circuits	3	0	0	3				
<i>Engr Science/Engr Design/Experiment/Depth Unit Totals</i>										

Program Totals (ABET Requirements)

Mathematics and Science		(45 units minimum)
Engineering Topics (Engr Science + Engr Design)		(68 units minimum)
Experimentation		(8 units minimum)

Program Approvals

Advisor

Printed Name: _____

Date: _____

Signature: _____

Departmental

Printed Name: _____

Date: _____

Signature: _____

School of Engineering

Printed Name: _____

Date: _____

Signature: _____

NOTES (continued from page 1)

- (2) Engr. Science and Design units (columns 1 and 2 combined) from Fundamentals and Depth must equal a minimum of 68 units to satisfy ABET requirements for graduation.
- (3) May take either EE 41 or EE 141.
- (4) Fulfills the "Writing in the Major" requirement. ENGR102E and EE108A must be taken concurrently.

Stanford University ♦ School of Engineering
Electrical Engineering - Computer Software
2006-2007 Sample Program Sheet
— ABET Accreditation Criteria Apply —

Completed and signed program sheet must be submitted to the department before the end of the quarter following the quarter in which the EE major is declared.
Final version of completed and signed program sheet due to the department no later than one month prior to the last quarter of senior year.

Name: _____ SU ID: _____
 Local Address: _____ Local Phone: _____
 _____ Email: _____
 _____ Date B.S. expected: _____

Mathematics and Science Requirement (Delete courses and units not taken)

Dept	Course	Title	Units				Grade	✓ if Transfer	Transfer/AP Approval	
			Engr Sci	Engr Des	Experiment	Total			Initials	Date
Mathematics										
MATH	41	Calculus (req'd)				5				
MATH	42	Calculus (req'd)				5				
MATH	51	Calculus (req'd; see note 1)				5				
MATH	52	Calculus (req'd; see note 1)				5				
MATH	53	Ordinary Differential Eqs (req'd; see note 1)				5				
STAT	116	Theory of Probability (req'd; see note 1)				5				
MATH	113	Linear Algebra and Matrix Theory				3				
						<i>Mathematics Unit Total</i>	33			
Science										
PHYS	41	Mechanics (req'd)			0	4				
PHYS	43	Electricity and Magnetism (req'd)			0	4				
PHYS	45	Optics and Thermodynamics			0	4				
						<i>Science Unit Total</i>	12	<i>(12 units minimum)</i>		
						<i>Mathematics and Science Unit Total</i>		<i>(45 units minimum)</i>		

Technology in Society Requirement (1 course required; see UGHB Fig. 3-3 for SoE approved list)

STS	110	Ethics and Public Policy				5				
-----	-----	--------------------------	--	--	--	---	--	--	--	--

NOTES

- * Engineering Science, Engineering Design, and Experimentation units do not apply to shaded areas.
 - * This form is available as an Excel file at <http://ughb.stanford.edu>. The printed form must be signed by the advisor and, if required, by the departmental representative. Changes must be initialed in ink. Delete courses not taken.
 - * All courses listed on this form must be taken for a letter grade if offered by the instructor.
 - * Minimum Combined Grade Point Average for all courses in Engineering Topics (Engineering Science and Engineering Design courses) is 2.0.
 - * Transfer and AP credits in Math, Science, Funds., & TIS must be approved by the SoE Dean's Office. Transfer credits in Engineering Depth must be approved by the Advisor. Transfer credit information and petitions are available at <http://ughb.stanford.edu/transfer.html>.
 - * All courses listed on this form must only be included under one category.
- (1) The CME math sequence (CME 100, 102, and 104 or 106) may be substituted for the MATH 51/52/53 sequence; CME 106, STAT 116 or MATH 151 may be substituted for EE178. Other substitutions require approval.

program sheet continues on page 2

Electrical Engineering/Computer Software Program Sheet (continued)

Engineering Topics (Engineering Science + Engineering Design; add columns 1 and 2. See Note 2)

Dept	Course	Title	Units				Grade	✓ if Transfer	Transfer/AP Approval	
			Engr Sci	Engr Des	Experiment	Total			Initials	Date
Engineering Fundamentals (3 courses required)										
ENGR	40	Introductory Electronics (recomm'd)	3	2	2	5				
ENGR	70X	Prog Meth and Abst (CS106X) (req'd)	4	1	0	5				
ENGR	60	Engineering Economy	3	0	0	3				
<i>Engineering Fundamentals Unit Total</i>						13				
Engineering Depth (Delete courses and units not taken)										
EE	12N	How Cyberspace Works	3	0	0	3				
EE	100	Electrical Engineering Profession (req'd)	0	0	0	0				
EE	41	Physics of Electrical Eng (req'd) (see note 3)	4	0	0	4				
EE	101A	Circuits I (req'd)	4	0	1	4				
EE	101B	Circuits II (req'd)	3	1	1	4				
EE	102A	Signal Processing and Linear Systems I (req'd)	4	0	1	4				
EE	102B	Signal Processing and Linear Systems II (req'd)	4	0	1	4				
ENGR	102E	Tech/Prof Writing (req'd) (see note 4)	0	0	0	0				
EE	108A	Digital Systems I (req'd) (see note 4)	3	1	1	4				
EE	108B	Digital Systems II (req'd)	3	1	1	4				
CS	107	Programming Paradigms	2	3	0	5				
CS	108	Object-Oriented Sys Design	2	2	0	4				
CS	244A	Introduction to Computer Networks	4	0	0	4				
CS	194	Software Project Laboratory	0	3	0	3				
EE	261	Fourier Transform and its Applications	3	0	0	3				
CS	255	Introduction to Cryptography	3	0	0	3				
EE	282	Computer Architecture and Organization	3	0	0	3				
CS	140	Operating Systems and Systems Progr								
<i>Engr Science/Engr Design/Experiment/Depth Unit Totals</i>										

Program Totals (ABET Requirements)

Mathematics and Science		(45 units minimum)
Engineering Topics (Engr Science + Engr Design)		(68 units minimum)
Experimentation		(8 units minimum)

Program Approvals

Advisor

Printed Name: _____

Date: _____

Signature: _____

Departmental

Printed Name: _____

Date: _____

Signature: _____

School of Engineering

Printed Name: _____

Date: _____

Signature: _____

NOTES (continued from page 1)

- (2) Engr. Science and Design units (columns 1 and 2 combined) from Fundamentals and Depth must equal a minimum of 68 units to satisfy ABET requirements for graduation.
- (3) May take either EE 41 or EE 141.
- (4) Fulfills the "Writing in the Major" requirement for Freshmen and Transfer students entering Fall 96 or later. ENGR102E and EE108A must be taken concurrently.

Stanford University ♦ School of Engineering
Electrical Engineering - Controls
2006-2007 Sample Program Sheet
— ABET Accreditation Criteria Apply —

Completed and signed program sheet must be submitted to the department before the end of the quarter following the quarter in which the EE major is declared.
Final version of completed and signed program sheet due to the department no later than one month prior to the last quarter of senior year.

Name: _____ SU ID: _____
 Local Address: _____ Local Phone: _____
 _____ Email: _____
 _____ Date B.S. expected: _____

Mathematics and Science Requirement (Delete courses and units not taken)

Dept	Course	Title	Units				Grade	✓ if Transfer	Transfer/AP Approval	
			Engr Sci	Engr Des	Experiment	Total			Initials	Date
Mathematics										
MATH	41	Calculus (req'd)				5				
MTH	42	Calculus (req'd)				5				
MATH	51	Calculus (req'd; see note 1)				5				
MATH	52	Calculus (req'd; see note 1)				5				
MATH	53	Ordinary Differential Eqs (req'd; see note 1)				5				
EE	178	Intro Prob Sys Anal (req'd; see note 1)				3				
MATH	113	Linear Algebra and Matrix Theory				3				
MATH	114	Linear Algebra and Matrix Theory II				3				
<i>Mathematics Unit Total</i>						34				
Science										
PHYS	41	Mechanics (req'd)			0	4				
PHYS	43	Electricity and Magnetism (req'd)			0	4				
PHYS	45	Optics and Thermodynamics			0	4				
<i>Science Unit Total</i>						12	<i>(12 units minimum)</i>			
<i>Mathematics and Science Unit Total</i>							<i>(45 units minimum)</i>			

Technology in Society Requirement (1 course required; see UGHB Fig. 3-3 for SoE approved list)

STS	113	Sci, Ethics, & Society: Debates & Controversies				5				
-----	-----	---	--	--	--	---	--	--	--	--

NOTES

- * Engineering Science, Engineering Design, and Experimentation units do not apply to shaded areas.
 - * This form is available as an Excel file at <http://ughb.stanford.edu>. The printed form must be signed by the advisor and, if required, by the departmental representative. Changes must be initialed in ink. Delete courses not taken.
 - * All courses listed on this form must be taken for a letter grade if offered by the instructor.
 - * Minimum Combined Grade Point Average for all courses in Engineering Topics (Engineering Science and Engineering Design courses) is 2.0.
 - * Transfer and AP credits in Math, Science, Funds., & TIS must be approved by the SoE Dean's Office. Transfer credits in Engineering Depth must be approved by the Advisor. Transfer credit information and petitions are available at <http://ughb.stanford.edu/transfer.html>.
 - * All courses listed on this form must only be included under one category.
- (1) The CME math sequence (CME 100, 102, and 104 or 106) may be substituted for the MATH 51/52/53 sequence; CME 106, STAT 116 or MATH 151 may be substituted for EE178. Other substitutions require approval.

program sheet continues on page 2

Electrical Engineering/Controls Program Sheet (continued)

Engineering Topics (Engineering Science + Engineering Design; add columns 1 and 2. See Note 2)

Dept	Course	Title	Units				Grade	✓ if Transfer	Transfer/AP Approval	
			Engr Sci	Engr Des	Experiment	Total			Initials	Date
Engineering Fundamentals (3 courses required)										
ENGR	40	Introductory Electronics (recomm'd)	3	2	2	5				
ENGR	70X	Prog Meth and Abst (CS106X) (req'd)	4	1	0	5				
ENGR	62	Introduction to Optimization	4	0	0	4				
<i>Engineering Fundamentals Unit Total</i>						14				
Engineering Depth (Delete courses and units not taken)										
EE	100	Electrical Engineering Profession (req'd)	0	0	0	1				
EE	41	Physics of Electrical Eng (req'd) (see note 3)	5	0	0	5				
EE	101A	Circuits I (req'd)	4	0	1	4				
EE	101B	Circuits II (req'd)	3	1	1	4				
EE	102A	Signal Processing and Linear Systems I (req'd)	4	0	1	4				
EE	102B	Signal Processing and Linear Systems II (req'd)	4	0	1	4				
ENGR	102E	Tech/Prof Writing (req'd) (see note 4)	0	0	0	1				
EE	108A	Digital Systems I (req'd) (see note 4)	3	1	1	4				
EE	108B	Digital Systems II (req'd)	3	1	1	4				
EE	122	Analog Laboratory	1	2	3	3				
ENGR	105	Feedback Control Design	1	2	0	3				
ENGR	205	Intro to Control Design Techniques	3	0	0	3				
ENGR	206	Control System Design & Simul	0	4	3	4				
ENGR	209A	Nonlinear Control	0	3	0	3				
EE	263	Intro to Linear Dynamical Systems	3	0	0	3				
EE	265	Signal Processing Laboratory	2.5	1.5	1	3				
EE	278	Intro to Statistical Signal Processing	3	0	0	3				
<i>Engr Science/Engr Design/Experiment/Depth Unit Totals</i>										

Program Totals (ABET Requirements)

Mathematics and Science		(45 units minimum)
Engineering Topics (Engr Science + Engr Design)		(68 units minimum)
Experimentation		(8 units minimum)

Program Approvals

Advisor

Printed Name: _____
Signature: _____

Date: _____

Departmental

Printed Name: _____
Signature: _____

Date: _____

School of Engineering

Printed Name: _____
Signature: _____

Date: _____

NOTES (continued from page 1)

- (2) Engr. Science and Design units (columns 1 and 2 combined) from Fundamentals and Depth must equal a minimum of 68 units to satisfy ABET requirements for graduation.
- (3) May take either EE 41 or EE 141.
- (4) Fulfills the "Writing in the Major" requirement for Freshmen and Transfer students entering Fall 96 or later. ENGR102E and EE108A must be taken concurrently.

Stanford University ♦ School of Engineering
Electrical Engineering - Circuits and Devices
2006-2007 Sample Program Sheet
— ABET Accreditation Criteria Apply —

Completed and signed program sheet must be submitted to the department before the end of the quarter following the quarter in which the EE major is declared.
Final version of completed and signed program sheet due to the department no later than one month prior to the last quarter of senior year.

Name: _____ SU ID: _____
 Local Address: _____ Local Phone: _____
 _____ Email: _____
 _____ Date B.S. expected: _____

Mathematics and Science Requirement (Delete courses and units not taken)

Dept	Course	Title	Units				Grade	✓ if Transfer	Transfer/AP Approval	
			Engr Sci	Engr Des	Experiment	Total			Initials	Date
Mathematics										
MATH	41	Calculus (req'd)				5				
MATH	42	Calculus (req'd)				5				
MATH	51	Calculus (req'd; see note 1)				5				
MATH	52	Calculus (req'd; see note 1)				5				
MATH	53	Ordinary Differential Eqs (req'd; see note 1)				5				
EE	178	Intro Probabilistic Sys Analysis (req'd; see note 1)				3				
<i>Mathematics Unit Total</i>										
Science										
PHYS	41	Mechanics (req'd)			0	4				
PHYS	43	Electricity and Magnetism (req'd)			0	4				
PHYS	45	Optics and Thermodynamics			0	4				
ESYS	10	Introduction to Earth Systems			0	5				
PHYS	46	Light and Heat Lab			1	1				
<i>Science Unit Total</i>							<i>(12 units minimum)</i>			
<i>Mathematics and Science Unit Total</i>							<i>(45 units minimum)</i>			

Technology in Society Requirement (1 course required; see UGHB Fig. 3-3 for SoE approved list)

STS	110	Ethics and Public Policy				5				
-----	-----	--------------------------	--	--	--	---	--	--	--	--

NOTES

- * Engineering Science, Engineering Design, and Experimentation units do not apply to shaded areas.
 - * This form is available as an Excel file at <http://ughb.stanford.edu>. The printed form must be signed by the advisor and, if required, by the departmental representative. Changes must be initialed in ink. Delete courses not taken.
 - * All courses listed on this form must be taken for a letter grade if offered by the instructor.
 - * Minimum Combined Grade Point Average for all courses in Engineering Topics (Engineering Science and Engineering Design courses) is 2.0.
 - * Transfer and AP credits in Math, Science, Funds., & TIS must be approved by the SoE Dean's Office. Transfer credits in Engineering Depth must be approved by the Advisor. Transfer credit information and petitions are available at <http://ughb.stanford.edu/transfer.html>.
 - * All courses listed on this form must only be included under one category.
- (1) The CME math sequence (CME 100, 102, and 104 or 106) may be substituted for the MATH 51/52/53 sequence; CME 106, STAT 116 or MATH 151 may be substituted for EE178. Other substitutions require approval.

program sheet continues on page 2

Electrical Engineering/Circuits Program Sheet (continued)

Engineering Topics (Engineering Science + Engineering Design; add columns 1 and 2. See Note 2)

Dept	Course	Title	Units				Grade	✓ if Transfer	Transfer/AP Approval	
			Engr Sci	Engr Des	Experiment	Total			Initials	Date
Engineering Fundamentals (3 courses required)										
ENGR	40	Introductory Electronics (recomm'd)	3	2	2	5				
ENGR	70X	Prog Meth and Abst (CS106X) (req'd)	4	1	0	5				
ENGR	50	Introductory Science of Materials	4	0	0	4				
<i>Engineering Fundamentals Unit Total</i>						14				
Engineering Depth (Delete courses and units not taken)										
EE	100	Electrical Engineering Profession (req'd)	0	0	0	1				
EE	41	Physics of Electrical Eng (req'd) (see note 3)	3	2	2	5				
EE	101A	Circuits I (req'd)	4	0	1	4				
EE	101B	Circuits II (req'd)	3	1	1	4				
EE	102A	Signal Processing and Linear Systems I (req'd)	4	0	1	4				
EE	102B	Signal Processing and Linear Systems II (req'd)	4	0	1	4				
ENGR	102E	Tech/Prof Writing (req'd) (see note 4)	0	0	0	1				
EE	108A	Digital Systems I (req'd) (see note 4)	3	1	1	4				
EE	108B	Digital Systems II (req'd)	3	1	1	4				
EE	114X	Intro to simulation-based Circuit Design	0.5	0.5	1	1				
EE	122	Analog Laboratory	1	2	3	3				
EE	116	Semiconductor Device Physics	3	0	0	3				
EE	133	Analog Communication Design Lab	0	3	2	3				
EE	212	Integrated Circuit Fabrication Processes	2	1	0	3				
EE	214	Bipolar Analog Integrated Circuits	0	3	0	3				
EE	216	Principles and Models of Semic. Devices	3	0	0	3				
EE	222	Applied Quantum Mechanics I	3	0	0	3				
EE	223	Applied Quantum Mechanics II	3	0	0	3				
EE	271	Intro to VLSI Systems	1.5	1.5	0	3				
<i>Engr Science/Engr Design/Experiment/Depth Unit Totals</i>										

Program Totals (ABET Requirements)

Mathematics and Science		(45 units minimum)
Engineering Topics (Engr Science + Engr Design)		(68 units minimum)
Experimentation		(8 units minimum)

Program Approvals

Advisor

Printed Name: _____
Signature: _____

Date: _____

Departmental

Printed Name: _____
Signature: _____

Date: _____

School of Engineering

Printed Name: _____
Signature: _____

Date: _____

NOTES (continued from page 1)

- (2) Engr. Science and Design units (columns 1 and 2 combined) from Fundamentals and Depth must equal a minimum of 68 units to satisfy ABET requirements for graduation.
- (3) May take either EE 41 or EE 141.
- (4) Fulfills the "Writing in the Major" requirement for Freshmen and Transfer students entering Fall 96 or later. ENGR102E and EE108A must be taken concurrently.

Stanford University ♦ School of Engineering
Electrical Engineering - Fields and Waves
2005-2006 Sample Program Sheet
— ABET Accreditation Criteria Apply —

Completed and signed program sheet must be submitted to the department before the end of the quarter following the quarter in which the EE major is declared.
Final version of completed and signed program sheet due to the department no later than one month prior to the last quarter of senior year.

Name: _____ SU ID: _____
 Local Address: _____ Local Phone: _____
 _____ Email: _____
 _____ Date B.S. expected: _____

Mathematics and Science Requirement (Delete courses and units not taken)

Dept	Course	Title	Units				Grade	✓ if Transfer	Transfer/AP Approval	
			Engr Sci	Engr Des	Experiment	Total			Initials	Date
Mathematics										
MATH	41	Calculus (req'd)				5				
MATH	42	Calculus (req'd)				5				
MATH	51	Calculus (req'd; see note 1)				5				
MATH	52	Calculus (req'd; see note 1)				5				
MATH	53	Ordinary Differential Eqs (req'd; see note 1)				5				
EE	178	Intro Prob Sys Anal (req'd; see note 1)				3				
MATH	113	Linear Algebra and Matrix Theory				3				
MATH	131	Partial Differential Equations I				3				
<i>Mathematics Unit Total</i>										
Science										
PHYS	41	Mechanics (req'd)			0	4				
PHYS	43	Electricity and Magnetism (req'd)			0	4				
PHYS	45	Optics and Thermodynamics			0	4				
<i>Science Unit Total</i>						12	<i>(12 units minimum)</i>			
<i>Mathematics and Science Unit Total</i>							<i>(45 units minimum)</i>			

Technology in Society Requirement (1 course required; see UGHB Fig. 3-3 for SoE approved list)

STS	110	Ethics and Public Policy				5				
-----	-----	--------------------------	--	--	--	---	--	--	--	--

NOTES

- * Engineering Science, Engineering Design, and Experimentation units do not apply to shaded areas.
 - * This form is available as an Excel file at <http://ughb.stanford.edu>. The printed form must be signed by the advisor and, if required, by the departmental representative. Changes must be initialed in ink. Delete courses not taken.
 - * All courses listed on this form must be taken for a letter grade if offered by the instructor.
 - * Minimum Combined Grade Point Average for all courses in Engineering Topics (Engineering Science and Engineering Design courses) is 2.0.
 - * Transfer and AP credits in Math, Science, Funds., & TIS must be approved by the SoE Dean's Office. Transfer credits in Engineering Depth must be approved by the Advisor. Transfer credit information and petitions are available at <http://ughb.stanford.edu/transfer.html>.
 - * All courses listed on this form must only be included under one category.
- (1) The CME math sequence (CME 100, 102, and 104 or 106) may be substituted for the MATH 51/52/53 sequence; CME 106, STAT 116 or MATH 151 may be substituted for EE178. Other substitutions require approval.

program sheet continues on page 2

Electrical Engineering/Fields and Waves Program Sheet (continued)

Engineering Topics (Engineering Science + Engineering Design; add columns 1 and 2. See Note 2)

Dept	Course	Title	Units				Grade	✓ if Transfer	Transfer/AP Approval	
			Engr Sci	Engr Des	Experiment	Total			Initials	Date
Engineering Fundamentals (3 courses required)										
ENGR	40	Introductory Electronics (recomm'd)	3	2	2	5				
ENGR	70X	Prog Meth and Abst (CS106X) (req'd)	4	1	0	5				
ENGR	14	Applied Mechanics	2	1	0	3				
<i>Engineering Fundamentals Unit Total</i>						13				
Engineering Depth (Delete courses and units not taken)										
EE	100	Electrical Engineering Profession (req'd)	0	0	0	1				
EE	141	Eng Electromagnetics (req'd) (see note 3)	4	0	0	4				
EE	101A	Circuits I (req'd)	4	0	1	4				
EE	101B	Circuits II (req'd)	3	1	1	4				
EE	102A	Signal Processing and Linear Systems I (req'd)	4	0	1	4				
EE	102B	Signal Processing and Linear Systems II (req'd)	4	0	1	4				
ENGR	102E	Tech/Prof Writing (req'd) (see note 4)	0	0	0	1				
EE	108A	Digital Systems I (req'd) (see note 4)	3	1	1	4				
EE	108B	Digital Systems II (req'd)	3	1	1	4				
EE	122	Analog Laboratory	1	2	3	3				
EE	142	Electromagnetic Waves	2.5	0.5	0	3				
EE	144	EM Waves Design Laboratory	1.5	1.5	1.5	3				
EE	179	Introduction to Communication	3	0	0	3				
EE	241	Waves I	3	0	0	3				
EE	247	Intro to Optical Fiber Comm	2	1	0	3				
EE	252	Antennas for Telecom. and Remote Sensing	2	1	0	3				
EE	261	Fourier Transform and Applications	3	0	0	3				
EE	278	Intro to Statistical Signal Processing	3	0	0	3				
EE	279	Intro to Communication Systems	3	0	0	3				
<i>Engr Science/Engr Design/Experiment/Depth Unit Totals</i>										

Program Totals (ABET Requirements)

Mathematics and Science		(45 units minimum)
Engineering Topics (Engr Science + Engr Design)		(68 units minimum)
Experimentation		(8 units minimum)

Program Approvals

Advisor

Printed Name: _____
Signature: _____

Date: _____

Departmental

Printed Name: _____
Signature: _____

Date: _____

School of Engineering

Printed Name: _____
Signature: _____

Date: _____

NOTES (continued from page 1)

- (2) Engr. Science and Design units (columns 1 and 2 combined) from Fundamentals and Depth must equal a minimum of 68 units to satisfy ABET requirements for graduation.
- (3) May take either EE 41 or EE 141.
- (4) Fulfills the "Writing in the Major" requirement for Freshmen and Transfer students entering Fall 96 or later. ENGR102E and EE108A must be taken concurrently.

Stanford University ♦ School of Engineering
Electrical Engineering - Signal Processing
2005-2006 Sample Program Sheet
— ABET Accreditation Criteria Apply —

Completed and signed program sheet must be submitted to the department before the end of the quarter following the quarter in which the EE major is declared.

Final version of completed and signed program sheet due to the department no later than one month prior to the last quarter of senior year.

Name: _____
 Local Address: _____

SU ID: _____
 Local Phone: _____
 Email: _____
 Date B.S. expected: _____

Mathematics and Science Requirement (Delete courses and units not taken)

Dept	Course	Title	Units				Grade	✓ if Transfer	Transfer/AP Approval	
			Engr Sci	Engr Des	Experiment	Total			Initials	Date
<i>Mathematics (see note 1)</i>										
MATH	41	Calculus (req'd)				5				
MATH	42	Calculus (req'd)				5				
MATH	51	Calculus (req'd; see note 1)				5				
MATH	52	Calculus (req'd; see note 1)				5				
MATH	53	Ordinary Differential Eqs (req'd; see note 1)				5				
EE	178	Intro Probabilistic Sys Analysis (req'd; see note 1)				3				
MATH	113	Linear Algebra and Matrix Theory				3				
<i>Mathematics Unit Total</i>										
<i>Science</i>										
PHYS	41	Mechanics (req'd)				0	4			
PHYS	43	Electricity and Magnetism (req'd)				0	4			
PHYS	45	Optics and Thermodynamics				0	4			
ESYS	10	Introduction to Earth Systems				1	4			
<i>Science Unit Total</i>							(12 units minimum)			
<i>Mathematics and Science Unit Total</i>							(45 units minimum)			

Technology in Society Requirement (1 course required; see UGHB Fig. 3-3 for SoE approved list)

STS	101	Sci., Tech., and Contemporary Society				4				
-----	-----	---------------------------------------	--	--	--	---	--	--	--	--

NOTES

- * Engineering Science, Engineering Design, and Experimentation units do not apply to shaded areas.
 - * This form is available as an Excel file at <http://ughb.stanford.edu>. The printed form must be signed by the advisor and, if required, by the departmental representative. Changes must be initialed in ink. Delete courses not taken.
 - * All courses listed on this form must be taken for a letter grade if offered by the instructor.
 - * Minimum Combined Grade Point Average for all courses in Engineering Topics (Engineering Science and Engineering Design courses) is 2.0.
 - * Transfer and AP credits in Math, Science, Funds., & TIS must be approved by the SoE Dean's Office. Transfer credits in Engineering Depth must be approved by the Advisor. Transfer credit information and petitions are available at <http://ughb.stanford.edu/transfer.html>.
 - * All courses listed on this form must only be included under one category.
- (1) The CME math sequence (CME 100, 102, and 104 or 106) may be substituted for the MATH 51/52/53 sequence; CME 106, STAT 116 or MATH 151 may be substituted for EE178. Other substitutions require approval.

program sheet continues on page 2

Electrical Engineering/Signal Processing Program Sheet (continued)

Engineering Topics (Engineering Science + Engineering Design; add columns 1 and 2. See Note 2)

Dept	Course	Title	Units				Grade	✓ if Transfer	Transfer/AP Approval	
			Engr Sci	Engr Des	Experiment	Total			Initials	Date
Engineering Fundamentals (3 courses required)										
ENGR	40	Introductory Electronics (recomm'd)	3	2	2	5				
ENGR	70X	Prog Meth and Abst (CS106X) (req'd)	4	1	0	5				
ENGR	62	Introduction to Optimization	4	0	0	4				
<i>Engineering Fundamentals Unit Total</i>						14				
Engineering Depth (Delete courses and units not taken)										
EE	100	Electrical Engineering Profession (req'd)	0	0	0	1				
EE	141	Eng Electromagnetics (req'd) (see note 3)	4	0	0	4				
EE	101A	Circuits I (req'd)	4	0	1	4				
EE	101B	Circuits II (req'd)	3	1	1	4				
EE	102A	Signal Processing and Linear Systems I (req'd)	4	0	1	4				
EE	102B	Signal Processing and Linear Systems II (req'd)	4	0	1	4				
ENGR	102E	Tech/Prof Writing (req'd) (see note 4)	0	0	0	1				
EE	108A	Digital Systems I (req'd) (see note 4)	3	1	1	4				
EE	108B	Digital Systems II (req'd)	3	1	1	4				
EE	122	Analog Laboratory	1	2	3	3				
EE	133	Analog Communications Laboratory	0	3	2	3				
EE	179	Introduction to Communication	3	0	0	3				
EE	261	Fourier Transforms	3	0	0	3				
EE	263	Intro. To Linear Dynamical Systems	3	0	0	3				
EE	265	Signal Processing Laboratory	2	1	3	3				
EE	276	Intro to Wireless Personal Comm	3	0	0	3				
EE	278	Intro to Statistical Signal Processing	3	0	0	3				
EE	279	Intro to Communication Systems	3	0	0	3				
<i>Engr Science/Engr Design/Experiment/Depth Unit Totals</i>										

Program Totals (ABET Requirements)

Mathematics and Science		(45 units minimum)
Engineering Topics (Engr Science + Engr Design)		(68 units minimum)
Experimentation		(8 units minimum)

Program Approvals

Advisor

Printed Name: _____

Date: _____

Signature: _____

Departmental

Printed Name: _____

Date: _____

Signature: _____

School of Engineering

Printed Name: _____

Date: _____

Signature: _____

NOTES (continued from page 1)

- (2) Engr. Science and Design units (columns 1 and 2 combined) from Fundamentals and Depth must equal a minimum of 68 units to satisfy ABET requirements for graduation.
- (3) May take either EE 41 or EE 141.
- (4) Fulfills the "Writing in the Major" requirement for Freshmen and Transfer students entering Fall 96 or later. ENGR102E and EE108A must be taken concurrently.

Stanford University ♦ School of Engineering
Electrical Engineering - Solid State and Photonic Devices
2006-2007 Sample Program Sheet
— ABET Accreditation Criteria Apply —

Completed and signed program sheet must be submitted to the department before the end of the quarter following the quarter in which the EE major is declared.

Final version of completed and signed program sheet due to the department no later than one month prior to the last quarter of senior year.

Name: _____
 Local Address: _____

SU ID: _____
 Local Phone: _____
 Email: _____
 Date B.S. expected: _____

Mathematics and Science Requirement (Delete courses and units not taken)

Dept	Course	Title	Units				Grade	✓ if Transfer	Transfer/AP Approval	
			Engr Sci	Engr Des	Experiment	Total			Initials	Date
<i>Mathematics</i>										
MATH	41	Calculus (req'd)				5				
MATH	42	Calculus (req'd)				5				
MATH	51	Calculus (req'd; see note 1)				5				
MATH	52	Calculus (req'd; see note 1)				5				
MATH	53	Ordinary Differential Eqs (req'd; see note 1)				5				
EE	178	Intro Prob Sys Anal (req'd; see note 1)				3				
MATH	113	Linear Algebra and Matrix Theory				3				
MATH	131	Partial Differential Equations I				3				
<i>Mathematics Unit Total</i>										
<i>Science</i>										
PHYS	41	Mechanics (req'd)			0	4				
PHYS	43	Electricity and Magnetism (req'd)			0	4				
PHYS	45	Optics and Thermodynamics			0	4				
<i>Science Unit Total</i>							<i>(12 units minimum)</i>			
<i>Mathematics and Science Unit Total</i>							<i>(45 units minimum)</i>			

Technology in Society Requirement (1 course required; see UGHB Fig. 3-3 for SoE approved list)

STS	110	Ethics and Public Policy				5				
-----	-----	--------------------------	--	--	--	---	--	--	--	--

NOTES

- * Engineering Science, Engineering Design, and Experimentation units do not apply to shaded areas.
 - * This form is available as an Excel file at <http://ughb.stanford.edu>. The printed form must be signed by the advisor and, if required, by the departmental representative. Changes must be initialed in ink. Delete courses not taken.
 - * All courses listed on this form must be taken for a letter grade if offered by the instructor.
 - * Minimum Combined Grade Point Average for all courses in Engineering Topics (Engineering Science and Engineering Design courses) is 2.0.
 - * Transfer and AP credits in Math, Science, Funds., & TIS must be approved by the SoE Dean's Office. Transfer credits in Engineering Depth must be approved by the Advisor. Transfer credit information and petitions are available at <http://ughb.stanford.edu>.
 - * All courses listed on this form must only be included under one category.
- (1) The CME math sequence (CME 100, 102, and 104 or 106) may be substituted for the MATH 51/52/53 sequence; CME 106, STAT 116 or MATH 151 may be substituted for EE178. Other substitutions require approval.

program sheet continues on page 2

Electrical Engineering/Solid State and Photonic Devices Program Sheet (continued)

Engineering Topics (Engineering Science + Engineering Design; add columns 1 and 2; see Note 2)

Dept	Course	Title	Units				Grade	✓ if Transfer	Transfer/AP Approval	
			Engr Sci	Engr Des	Experiment	Total			Initials	Date
Engineering Fundamentals (3 courses required)										
ENGR	40	Introductory Electronics (recomm'd)	3	2	2	5				
ENGR	70X	Prog Meth and Abst (CS106X) (req'd)	4	1	0	5				
ENGR	14	Applied Mechanics	2	1	0	3				
<i>Engineering Fundamentals Unit Total</i>										
Engineering Depth (Delete courses and units not taken)										
EE	41	Physics of Electrical Engr (req'd) (see note 3)	4	0	0	4				
EE	100	Electrical Engineering Profession (req'd)	0	0	0	1				
EE	101A	Circuits I (req'd)	4	0	1	4				
EE	101B	Circuits II (req'd)	3	1	1	4				
EE	102A	Signal Processing and Linear Sys I (req'd)	4	0	1	4				
EE	102B	Signal Processing and Linear Sys II (req'd)	4	0	1	4				
ENGR	102E	Tech/Prof Writing (req'd) (see note 4)	0	0	0	1				
EE	108A	Digital Systems I (req'd) (see note 4)	3	1	1	4				
EE	108B	Digital Systems II (req'd)	3	1	1	4				
EE	122	Analog Laboratory	1	2	3	3				
EE	235	Guide Wave Optical Devices	3	0	0	3				
EE	134	Intro. to Photonics	1	2	3	3				
EE	141	Engineering Electromagnetics	4	0	0	4				
EE	142	Electromagnetic Waves	2.5	0.5	0	3				
EE	116	Semiconductor Device Physics	3	0	0	3				
EE	216	Princ and Models of Semiconductor Physics	3	0	0	3				
EE	222	Applied Quantum Mechanics	3	0	0	3				
EE	223	Applied Quantum Mechanics	3	0	0	3				
EE	228	Basic Physics for Solid State Devices	3	0	0	3				
<i>Engr Science/Engr Design/Experiment/Depth Unit Totals</i>										

Program Totals (ABET Requirements)

<i>Mathematics and Science</i>		<i>(45 units minimum)</i>
<i>Engineering Topics (Engr Science + Engr Design)</i>		<i>(68 units minimum)</i>
<i>Experimentation</i>		<i>(8 units minimum)</i>

Program Approvals

Advisor

Printed Name: _____
Signature: _____

Date: _____

Departmental

Printed Name: _____
Signature: _____

Date: _____

School of Engineering

Printed Name: _____
Signature: _____

Date: _____

NOTES (continued from page 1)

- (2) Engr. Science and Design units (columns 1 and 2 combined) from Fundamentals and Depth must equal a min. of 68 units to satisfy ABET requirements for graduation.
- (3) May take either EE 41 or EE 141.
- (4) Fulfills the "Writing in the Major" requirement for Freshmen and Transfer students entering Fall 96 or later. ENGR102E and EE108A must be taken concurrently.